

# Temposonics®

Absolute, Non-Contact Position Sensors



**MH-Series**  
SAE J1939 Standard

**Protocol Manual**



## 1 History

Ver.	By	Date	Changes	Areas Affected	Comments
0.1	PL	20.07.10	First released		
0.2	PL	11.02.11	Over temperature value changed	12	

## 2 Index of Contents

<b>1</b>	<b>History</b> .....	<b>1</b>
<b>2</b>	<b>Index of Contents</b> .....	<b>2</b>
<b>3</b>	<b>List of Figures</b> .....	<b>3</b>
<b>4</b>	<b>List of Tables</b> .....	<b>3</b>
<b>5</b>	<b>Abbreviations</b> .....	<b>4</b>
<b>6</b>	<b>General functionality</b> .....	<b>4</b>
<b>7</b>	<b>J1939-21 Data Link</b> .....	<b>4</b>
7.1	Protocol Data Unit .....	4
7.2	Parameter Group Number .....	6
7.3	Parameter Group Number Proprietary B .....	7
7.4	Transport Protocol .....	7
7.4.1	Multi-Packet Broadcast message .....	8
<b>8</b>	<b>J1939-81 Network Management</b> .....	<b>10</b>
8.1	Network State Machine .....	10
8.2	J1939 NAME definition .....	11
8.3	Address Management messages .....	12
8.3.1	Address Claimed message .....	12
8.3.2	Cannot Claim Source Address .....	13
8.3.3	Request message for Address Claimed (PGN 60928) .....	14
8.4	Address Configuration .....	15
8.4.1	Commanded Address message .....	15
8.5	Network Error Management .....	17
<b>9</b>	<b>J1939-74 Application Configurable Messaging</b> .....	<b>18</b>
9.1	Configuration NAME .....	18
9.2	Configuration Transmission Repetition Rates (Update Rates) .....	20
9.3	Configuration Data Record Parameter Group Number .....	21
<b>10</b>	<b>J1939-71 Application Layer</b> .....	<b>22</b>
10.1	Software Identification .....	22
10.2	Component Identification .....	23
10.3	Parameter Information .....	24
<b>11</b>	<b>J1939-73 Application Layer Diagnostics</b> .....	<b>25</b>
11.1	Stop Start Broadcast (DM13) .....	25
<b>12</b>	<b>Data Record Message</b> .....	<b>28</b>
<b>13</b>	<b>Literature</b> .....	<b>31</b>

### 3 List of Figures

Figure 1	J1939 Extended CAN Data Frame definition .....	4
Figure 2	PDU Specific definition.....	5
Figure 3	Parameter Group Number.....	6
Figure 4	Broadcast Announce Message Data Transfer .....	9
Figure 5	Power on State Transition Diagram .....	10
Figure 6	Address Claimed message .....	12
Figure 7	Cannot Claim Address message.....	13
Figure 8	Request message for Address Claimed.....	14
Figure 9	Programming NAME .....	19
Figure 10	Programming Transmission rate .....	20
Figure 11	Programming Data Record PGN.....	21
Figure 12	Request Software Identification Sequence .....	22
Figure 13	Request Component Identification Sequence.....	23
Figure 14	Stop Broadcast Current Data Link .....	26
Figure 15	Start Broadcast Current Data Link .....	26
Figure 16	Stop Broadcast J1939 Network #1.....	26
Figure 17	Start Broadcast J1939 Network #1 .....	26
Figure 18	DM13 Hold signal .....	27
Figure 19	Data Record message.....	28
Figure 20	Sensor Error Code Register definition .....	30
Figure 21	Sensor Limit Status Register definition .....	31

### 4 List of Tables

Table 1	PGN Proprietary B Specification .....	7
Table 2	MH J1939 J01 Proprietary B Data Field.....	7
Table 3	TP.CM PGN Specification .....	8
Table 4	TP.CM Broadcast Announce Message (BAM) Data Field .....	8
Table 5	TP.DT PGN Specification.....	8
Table 6	TP.DT PGN Data Field.....	9
Table 7	NAME Fields.....	11
Table 8	Address Claimed message Specification .....	12
Table 9	NAME Layout in the Address Claimed message .....	12
Table 10	Cannot Claim Address message Specification .....	13
Table 11	NAME Layout in the Cannot Claim Address message.....	13
Table 12	Cannot Claim Address message Specification .....	14
Table 13	Request message for Address Data field.....	14
Table 14	Commanded Address message Specification .....	15
Table 15	Commanded Address Target NAME.....	15
Table 16	Commanded Address New source Address .....	15
Table 17	NAME Fields.....	18
Table 18	Destination Specific Proprietary Configurable Message 1 Specification.....	18
Table 19	Layout of the Destination Specific Proprietary Configurable Message 1 .....	19
Table 20	Destination Specific Proprietary Configurable Message 2 Specification.....	20
Table 21	Layout of the Destination Specific Proprietary Configurable Message 2 .....	20
Table 22	Destination Specific Proprietary Configurable Message 3 Specification.....	21
Table 23	Layout of the Destination Specific Proprietary Configurable Message 3 .....	21
Table 24	Software Identification Specification.....	22
Table 25	Layout of the MTS Software Identification Message.....	22
Table 26	Component Identification Specification .....	23
Table 27	Layout of the MTS Component Identification Message .....	23
Table 28	Stop Start Message Specification .....	25
Table 29	Layout of the Stop Start Message .....	25
Table 30	DM13 Bit definitions.....	26
Table 31	DM13 Hold Signal Bit definitions .....	27
Table 32	Data Record PGN Specification .....	28
Table 33	MH J1939 J01 Data Record message Data Field.....	28

## 5 Abbreviations

Tx	–	MH CAN J1939 Standard Sensor is the producer of the CAN Data frame.
Rx	–	MH CAN J1939 Standard Sensor is the consumer of the CAN data frame.
SDO	–	Service Data Object
CiA	–	CAN in Automation e.V.
ro	–	Read only
rw	–	Read Write
wo	–	Write only
SAE	–	Society of Automotive Engineers
CA	–	Controller Application
SA	–	Source Address
BAM	–	Broadcast Announce Message
PGN	–	Parameter Group Number
TP	–	Transport Protocol
DM	–	Diagnostic Messages

## 6 General functionality

This document reflects the MTS MH CAN J1939 Standard Sensor protocol implementation of the MTS Standard J01 protocol.

The Sensor supports the basic J1939 functionality like the Address claiming.

The MH CAN J1939 Standard Sensor is designed as a Command Configurable Address CA.

For the Data Record of the Magnet Position, Limit and Status information the MH CAN J1939 Standard Sensor uses the manufacturer specific Parameter Group 'Proprietary B'.

## 7 J1939-21 Data Link

This chapter gives us general information about using the CAN protocol with extended 29-bit CAN Identifiers. This CAN 29-bit CAN Frame format is the only format for J1939 CAN messages. But Standard 11-bit CAN Frames can reside on the network.

### 7.1 Protocol Data Unit

The Protocol Data Unit provides a framework for organizing the information that is the key to each CAN Data Frame that is send. The extended CAN Data Frame used for the SAE J1939 protocol is separated in seven fields. The 29-bit Identifier is separated in 6 fields.

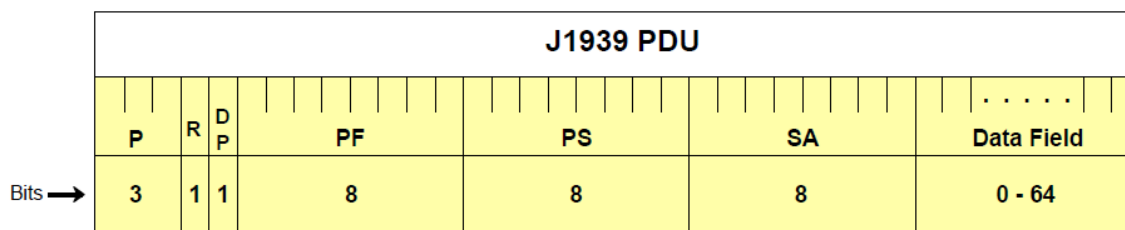

Definitions: P is Priority, R is Reserved, DP is Data Page, PF is PDU Format, PS is PDU Specific, and SA is Source Address

**Figure 1 J1939 Extended CAN Data Frame definition**

**P – Priority**

These three bits are used to optimize message latency for transmission. 3-bits

**R – Reserved**

Always 0. 1-bit

**DP – Data Page**

Only 0 used. 1-bit

**PF – PDU Format**

This field is used to determine the Parameter Group Number (PGN). Parameter Group Numbers identify or label information that require one or more CAN Data Frames to communicate the information. The PDU Format is the mid byte of the Parameter Group Number.

**PS – PDU Specific**

This field depends upon the value of the PDU Format. Depending on the PDU Format it can be a Destination Address or a Group Extension. If the value of the PDU Format field is below 240, then the PDU specific field is a destination address. If the value of the PDU Format field is 240 to 255, then the PDU specific field contains a Group Extension value. The PDU2 Format messages are global messages.

	<b>PDU Format Field</b>	<b>PDU Specific Field</b>
PDU1 Format	0-239	Destination Address
PDU2 Format	240-255	Group Extension

**Figure 2 PDU Specific definition**

**Destination Address (DA)**

This field defines the specific address to which the message is being sent. Any other should ignore this message. The global destination address (255) requires all devices to listen and respond accordingly as message recipients.

**Group Extension (GE)**

The Group Extension field provides 4096 Parameter Groups per page.

**SA – Source Address**

There should only be one device on the network with a given source address. Therefore, the Source Address field assures that the CAN Identifier is unique, as required by CAN.

**Data Field**

The J1939 Protocol Data Unit (PDU) can contain up to 8bytes as defined in the CAN data frame. But a Parameter Group can contain up to 1785 Bytes. Therefore a multipacket transmission must be used for that situation. This multipacket transmission is defined in the J1939 Transport protocol. The MH CAN J1939 Standard Sensor supports only Transport protocol for the Source Address Configuration (8.4.1 Commanded Address message)

## 7.2 Parameter Group Number

The PGN uniquely identifies the Parameter Group (PG) that is being transmitted in the message. Each PG (a grouping of specific parameters) has a definition that includes the assignment of each parameter within the 8-byte data field (size in bytes, location of LSB), and the transmission rate and priority of the message.

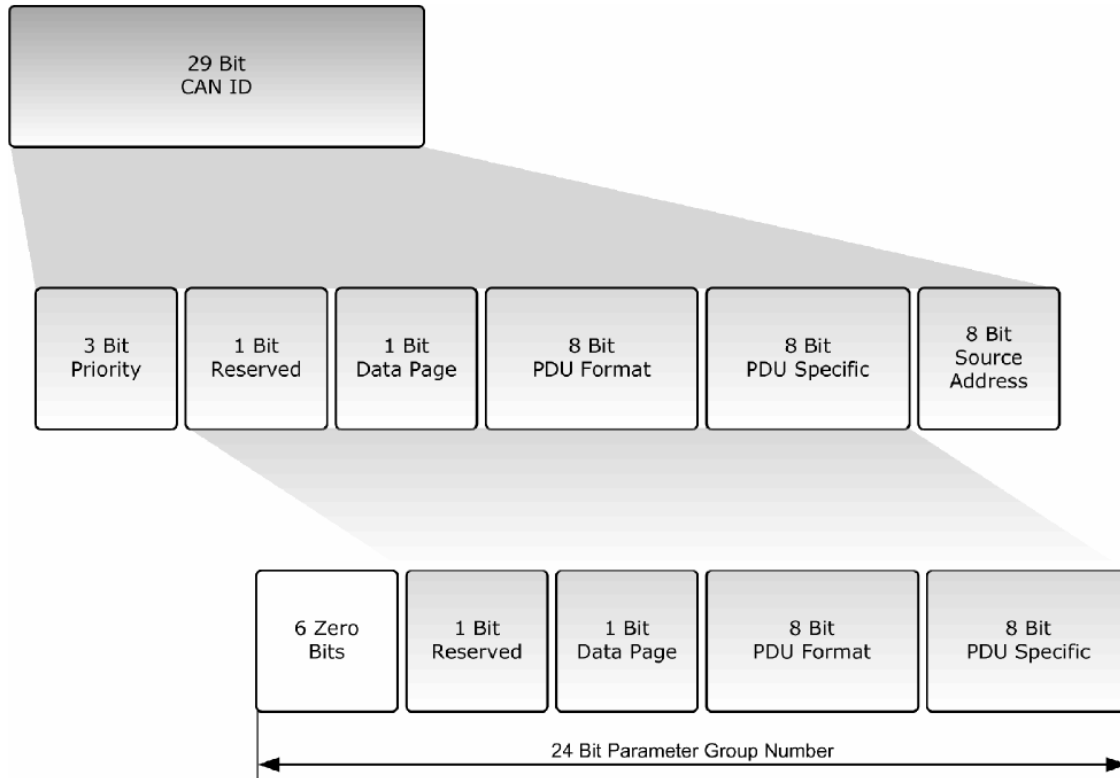

**Figure 3 Parameter Group Number**

For internal purposes the Parameter Group Number is extended to 24bits. For the MH CAN J1939 Standard Sensor only the Data Page 0 is supported. The reserved bit is set to zero, that means the high-byte of the Parameter Group number is always zero.

### 7.3 Parameter Group Number Proprietary B

This Parameter Group Number is for manufacturer specific purposes. It uses the PDU2 Format. The Data Length has to be defined by the manufacturer.

<b>Parameter Group Number Proprietary B</b>	
Transmission rate:	Per user requirements
Data length	8 bytes (general 0-1785)
Data page	0
PDU format	255
PDU specific	Group Extension
Default priority	6
Parameter Group Number	65280 to 65535 (00FF00 <sub>16</sub> to 00FFFF <sub>16</sub> )
Source Address	0 to 253

**Table 1 PGN Proprietary B Specification**

For the MH CAN J1939 Standard Sensor the Parameter Group Number Proprietary B is used for the Data Record message.

<b>Data Field</b>	
Byte D0 Bits 8-1	Least significant byte of the Position
Byte D1 Bits 8-1	Most significant byte of the Position
Byte D2 Bits 8-1	Least significant byte of the Velocity
Byte D3 Bits 8-1	Most significant byte of the Velocity
Byte D4 Bits 8-1	Status
Byte D5 Bits 8-1	Error Code
Byte D6 Bits 8-1	Limit Status
Byte D7 Bits 8-1	0xFF

**Table 2 MH J1939 J01 Proprietary B Data Field**

The Transmission rate and the PDU specific value can be changed by the user with the Application Configurable Messaging (see 9 J1939-74 Application Configurable Messaging )

### 7.4 Transport Protocol

Some Parameter Group numbers are defined with a Data Length of more than 8 bytes. Since a CAN Data frame is only limited to only 8 bytes per message, the Parameter Group needs to be packed into a sequence of 8 byte size messages.

Such functions, like message packaging and reassembly, are defined as Transport Protocol (TP).

For the MH CAN J1939 Standard Sensor the Transport Protocol is only used for the SAE J1939 command 'Commanded Address' to program a new Source Address. And this command uses only the Multi-Packet Broadcast message.



## 7.4.1 Multi-Packet Broadcast message

The Multi-Packet Broadcast message is sent to the Global Address of the J1939 network. This message consists of two kinds of message.

### Transport Protocol – Connection Management (TP.CM)

In order to broadcast a multi-packet message a node must first send a **Broadcast Announce Message (BAM)**. The Broadcast Announce Message is embedded in the Transport Protocol – Connection Management.

Transport Protocol – Connection Management	
Transmission rate:	As required
Data length	8 bytes
Data page	0
PDU format	236
PDU specific	255 (global address)
Default priority	7
Parameter Group Number	60416 (00EC00) <sub>16</sub>
Source Address	0 to 253

**Table 3 TP.CM PGN Specification**

Transport Protocol – Connection Management	
Byte 1	Control byte = 32 (0x20 <sub>16</sub> ) for BAM
Byte 2	Message size (low-byte)
Byte 3	Message size (high-byte)
Byte 4	Total number of packages
Byte 5	Reserved = 255 (0xFF <sub>16</sub> )
Byte 6	Parameter Group Number (low-byte)
Byte 7	Parameter Group Number (mid-byte)
Byte 8	Parameter Group Number (high-byte)

**Table 4 TP.CM Broadcast Announce Message (BAM) Data Field**

### Transport Protocol – Data Transfer (TP.DT)

Transport Protocol – Data Transfer	
Transmission rate:	As required
Data length	8 bytes
Data page	0
PDU format	235
PDU specific	255 (global address)
Default priority	7
Parameter Group Number	60160 (00EB00) <sub>16</sub>
Source Address	0 to 253

**Table 5 TP.DT PGN Specification**

Transport Protocol – Data Transfer	
Byte 1	Sequence number (1-255)
Byte 2	Data
Byte 3	Data
Byte 4	Data
Byte 5	Data
Byte 6	Data
Byte 7	Data
Byte 8	Data

**Table 6 TP.DT PGN Data Field**

The last packet of a multi-packet PGN may require less than eight data bytes. All unused data bytes in the last package are being set to 255 (0xFF<sub>16</sub>).

**Timing requirements**

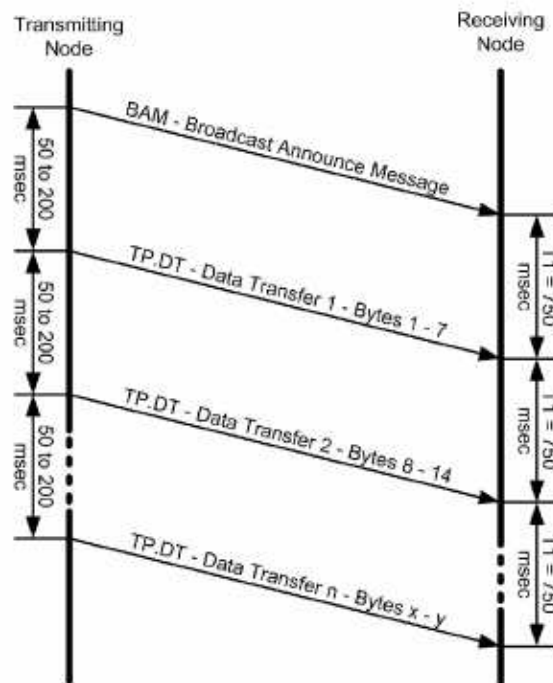

**Figure 4 Broadcast Announce Message Data Transfer**

The message packet time interval will be between 50 and 200ms.  
A timeout will occur when a time of greater than 750ms elapsed between two messages. The connection is then closed.  
The connection is also closed when the last Data Transfer package (TP.DT) is send.

## 8 J1939-81 Network Management

The Network management in the SAE J1939 network handles the source address management and the association of those addresses with an actual function and with the detection and reporting of network related errors. The network management also specifies the initialization process.

### 8.1 Network State Machine

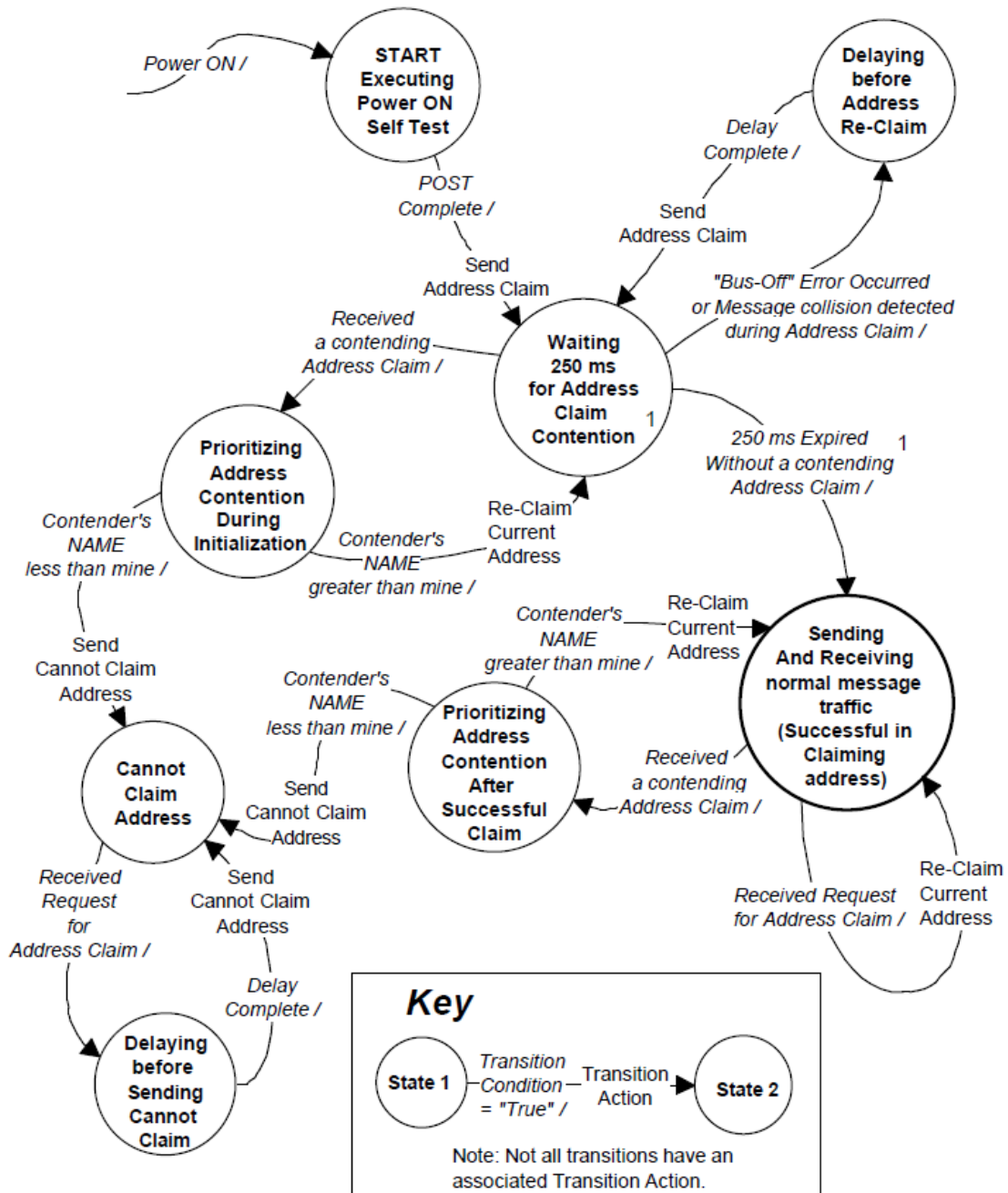

Figure 5 Power on State Transition Diagram

1 - CAs claiming addresses in the 0-127 and 248-253 ranges may omit the 250ms delay.

After Power on the Address Claimed message is send to the network by the MH CAN J1939 Standard Sensor. This message is a global message which is received by any CA of the network. This message contains the Source Address and a unique NAME of the MH CAN J1939 Standard Sensor.

If the MH CAN J1939 Standard Sensor receives no other Address Claimed message with the same Source Address, than the MH CAN J1939 Standard Sensor starts the transmission of the normal Data Record message. The transmission starts immediately after the transmission of the Address Claimed message or with a delay of 250ms when the Source Address is in the range of 128-247.

If the MH CAN J1939 Standard Sensor receives an Address Claimed message with the same Source Address than the MH CAN J1939 Standard Sensor has to compare the receiving NAME and its own NAME.

If the receiving NAME is lower than mine, then the MH CAN J1939 Standard Sensor has to use the NULL Address (254) as the Source Address and has to send the Cannot Claim Address message. The transmission of the Cannot Claim message is always delayed with a pseudo random delay of 0-153ms.

When the MH CAN J1939 Standard Sensor has the NULL Address as its Source Address then the MH CAN J1939 Standard Sensor does not send the normal Data Record message.

If the receiving NAME is higher than mine, the MH CAN J1939 Standard Sensor sends the Address Claim message again and starts or continuing the transmission of the Data record message with a 250ms delay when the Source Address is in the range of 128-247.

If a CAN Bus-Off Error condition occurs then, the MH CAN J1939 Standard Sensor has to send its Address Claimed message again with a pseudo random delay of 0-153ms.

## 8.2 J1939 NAME definition

Every CA that transmits messages on a SAE J1939 network must have a unique NAME and successfully acquire an Address before the CA may transmit normal network traffic. The NAME serves two purposes, first to provide a functional description of the CA and second to provide a numerical value that may be used in the network management for addresses.

NAMEs are composed of fields as shown in Table 1 and 2, and are defined in the following paragraphs.

Table 1: NAME Fields

Arbitrary Address Capable	Industry Group	Vehicle System Instance	Vehicle System	Reserved	Function	Function Instance	ECU Instance	Manufacturer Code	Identity Number		
1 bit 4.1.1.2	3 bit 4.1.1.3	4 bit 4.1.1.4	7 bit 4.1.1.5	1 bit 4.1.1.6	8 bit 4.1.1.7	5 bit 4.1.1.8	3 bit 4.1.1.9	11 bit 4.1.1.10	21 bit 4.1.1.11		
Byte 8			Byte 7		Byte 6	Byte 5		Byte 4	Byte 3	Byte 2	Byte 1

Table 7 NAME Fields

Due to the reason that MTS does not know the final application of the MH CAN J1939 Standard Sensor the four high bytes are free programmable values (except the Arbitrary Address Capable bit) by the customer. (9.1 Configuration NAME)

The manufacturer code is fixed to the value 265 for MTS Sensor Technologie.  
The Identity number is a unique value which is programmed by MTS.

## 8.3 Address Management messages

### 8.3.1 Address Claimed message

The Address Claimed message is send by the MH CAN J1939 Standard Sensor after

- every Power On
- a request for Address Claimed command
- a re-claim situation when receiving a Address Claimed message with the same Source Address
- programming a new Source Address
- programming a new NAME

Address Claimed message	
Transmission rate:	As required
Data length	8 bytes
Data page	0
PDU format	238
PDU specific	255 (global address)
Default priority	6
Parameter Group Number	60928 (00EE00) <sub>16</sub>
Source Address	0 to 253

**Table 8 Address Claimed message Specification**

NAME	
Byte D0 Bits 8-1	Least significant byte of Identity Number
Byte D1 Bits 8-1	Second byte of Identity Number
Byte D2 Bits 8-6 Bits 5-1	Least significant 3 bits of Manufacturer Code Most significant 5 bits of Identity Number
Byte D3 Bits 8-1	Most significant bits of Manufacturer Code
Byte D4 Bits 8-4 Bits 3-1	Function Instance ECU Instance
Byte D5 Bits 8-1	Function
Byte D6 Bits 8-2 Bit 1	Vehicle System Reserved
Byte D7 Bit 8 Bits 7-5 Bits 4-1	Arbitrary Address Capable Industry Group Vehicle System Instance

**Table 9 NAME Layout in the Address Claimed message**

**Example:**

COB-ID	Rx/Tx	DLC	Data							
			D0	D1	D2	D3	D4	D5	D6	D7
0x18EEFF00 + Source Address	Tx/Rx	8	See Table 9 NAME Layout in the Address Claimed message							

**Figure 6 Address Claimed message**

### 8.3.2 Cannot Claim Source Address

The Cannot Claim Source Address message is send by the MH CAN J1939 Standard Sensor after

- a request for Address Claimed command and a NULL Address (254) as Source Address
- receiving a Address Claimed message with the same Source Address and a lower NAME than mine

Address Claimed message	
Transmission rate:	As required
Data length	8 bytes
Data page	0
PDU format	238
PDU specific	255 (global address)
Default priority	6
Parameter Group Number	60928 (00EE00) <sub>16</sub>
Source Address	254

**Table 10 Cannot Claim Address message Specification**

NAME	
Byte D0 Bits 8-1	Least significant byte of Identity Number
Byte D1 Bits 8-1	Second byte of Identity Number
Byte D2 Bits 8-6 Bits 5-1	Least significant 3 bits of Manufacturer Code Most significant 5 bits of Identity Number
Byte D3 Bits 8-1	Most significant bits of Manufacturer Code
Byte D4 Bits 8-4 Bits 3-1	Function Instance ECU Instance
Byte D5 Bits 8-1	Function
Byte D6 Bits 8-2 Bit 1	Vehicle System Reserved
Byte D7 Bit 8 Bits 7-5 Bits 4-1	Arbitrary Address Capable Industry Group Vehicle System Instance

**Table 11 NAME Layout in the Cannot Claim Address message**

**Example:**

COB-ID	Rx/Tx	DLC	Data							
			D0	D1	D2	D3	D4	D5	D6	D7
0x18EEFFFE	Tx/Rx	8	See Table 9 NAME Layout in the Address Claimed message							

**Figure 7 Cannot Claim Address message**

### 8.3.3 Request message for Address Claimed (PGN 60928)

The Request message for Address Claimed can be used to force the MH CAN J1939 Standard Sensor to send the Address Claimed message or the Cannot Claim Address message depending upon the actual Source Address.

Request message for Address	
Transmission rate:	As required
Data length	3 bytes
Data page	0
PDU format	234
PDU specific	Destination Address (global or specific)
Default priority	6
Parameter Group Number	59904 (00EA00) <sub>16</sub>
Source Address	Don't care (except own SA)

**Table 12 Cannot Claim Address message Specification**

Data Field (PGN Address Claimed message)	
Byte D0	0x00 (PGN low byte)
Byte D1	0xEE (PGN mid byte)
Byte D2	0x00 (PGN high byte)

**Table 13 Request message for Address Data field**

**Example:**

COB-ID	Rx/Tx	DLC	Data							
			D0	D1	D2	D3	D4	D5	D6	D7
0x18EASAMA	Rx	3	0x00	0xEE	0x00	-	-	-	-	-

**Figure 8 Request message for Address Claimed**

**SA** – MH CAN J1939 Standard Sensor Source Address or 0xFF (global Address)

**MA** – Masters Source Address (all values possible except the own Source Address)

## 8.4 Address Configuration

The MH CAN J1939 Standard Sensor is a Command Configurable Address CA. A Command Configurable Address CA is one whose Source Address can be altered using the Commanded Address message.

### 8.4.1 Commanded Address message

The Commanded Address message is sent with the Transport Protocol BAM defined in the SAE J1939-21 (see 7.4 Transport Protocol).

Commanded Address message	
Transmission rate:	As required
Data length	9 bytes
Data page	0
PDU format	254
PDU specific	216
Default priority	6
Parameter Group Number	65240 (00FED8 <sub>16</sub> )
Source Address	

**Table 14 Commanded Address message Specification**

NAME of Commanded Address Target	
Byte 1 Bits 8-1	Least significant byte of Identity Number
Byte 2 Bits 8-1	Second byte of Identity Number
Byte 3 Bits 8-6 Bits 5-1	Least significant 3 bits of Manufacturer Code Most significant 5 bits of Identity Number
Byte 4 Bits 8-1	Most significant bits of Manufacturer Code
Byte 5 Bits 8-4 Bits 3-1	Function Instance ECU Instance
Byte 6 Bits 8-1	Function
Byte 7 Bits 8-2 Bit 1	Vehicle System Reserved
Byte 8 Bit 8 Bits 7-5 Bits 4-1	Arbitrary Address Capable Industry Group Vehicle System Instance

**Table 15 Commanded Address Target NAME**

Address Assignment (new Source Address)	
Byte 9 Bits 8-1	New Source Address Data range: 0-253

**Table 16 Commanded Address New source Address**



**Example:**

COB-ID	Rx/Tx	DLC	Data							
			D0	D1	D2	D3	D4	D5	D6	D7
0x1CECFFMA	Rx	8	0x20	0x09	0x00	0x02	0xFF	0xD8	0xFE	0x00

COB-ID	Rx/Tx	DLC	Data							
			D0	D1	D2	D3	D4	D5	D6	D7
0x1CEBFFMA	Rx	8	0x01	See Table 15 Commanded Address Target NAME Byte 1 to Byte 7						

COB-ID	Rx/Tx	DLC	Data							
			D0	D1	D2	D3	D4	D5	D6	D7
0x1CEBFFMA	Rx	8	0x02	See Table 15 Commanded Address Target NAME Byte 8	See Table 16 Commanded Address New source Address Byte 9	0xFF	0xFF	0xFF	0xFF	0xFF

**MA** – Masters Source Address (all values possible except the own Source Address)

The maximum Time between each message is **750ms** otherwise the Transport Protocol BAM is aborted.

**Note:** The new Source Address gets immediately active. The new Source Address is stored in the non-volatile memory of the MH CAN J1939 Standard Sensor, so with the next Power On the MH CAN J1939 Standard Sensor uses the new Source Address.

An Address Claimed message is send, after successful programming, by the MH CAN J1939 Standard Sensor to avoid a Network Error if another device uses the same Source Address.

## **8.5 Network Error Management**

In the SAE J1939 network every device must have a unique Source Address. The Source Address range is 0-253.

The Source Address 254 is the NULL Address, is reserved for network Management and it used for the 8.3.2 Cannot Claim Source Address.

The Source Address 255 is exclusively used as a destination address in order to support message broadcasting.

A Source Address conflict can occur when two or more devices claim the same Source Address. So every time when a device is receiving a 8.3.1 Address Claimed message with its own Source Address, the device has to compare the NAME of the Address Claimed message. The device with the lowest NAME value will succeed and use the Source Address as claimed. The remaining devices must claim a different Source Address or stop transmitting to the network by using the NULL Address. Also the remaining device sends the Address Claimed message. The other devices may send the 8.3.2 Cannot Claim Source Address with a pseudo random delay of 0-153ms.

There is a small probability that two or more devices with the same Source Address send the Address Claimed message or the Cannot Claim Source Address at the same time. The CAN Identifier of these messages is equal, but the Data Field is different. This situation can lead to a CAN Error or CAN Bus-Off state of the device. If this happens then the device has to send the message again with a pseudo random delay of 0-153ms.

**Note:** If the MH CAN J1939 Standard Sensor has the higher NAME at a Source Address conflict, the MH CAN J1939 Standard Sensor claims the NULL Address and stops the Data Record transmission. Only the 8.3.3 Request message for Address Claimed (PGN 60928) and the 8.4.1 Commanded Address message are possible.

## 9 J1939-74 Application Configurable Messaging

The MH CAN J1939 Standard Sensor can be used in many different applications and different network requirements. So the user now has the possibility to change some parameters by using the J1939-74 Application Configurable messaging.

**Note:** Only the Destination Specific Proprietary Configurable Messages 1-3 are implemented in the MH CAN J1939 Standard Sensor. All other services are not supported.

### 9.1 Configuration NAME

The NAME of the MH CAN J1939 Standard Sensor can be different depending upon the application.

NAMEs are composed of fields as shown in Table 1 and 2, and are defined in the following paragraphs.

**Table 1: NAME Fields**

Arbitrary Address Capable	Industry Group	Vehicle System Instance	Vehicle System	Reserved	Function	Function Instance	ECU Instance	Manufacturer Code	Identity Number		
1 bit 4.1.1.2	3 bit 4.1.1.3	4 bit 4.1.1.4	7 bit 4.1.1.5	1 bit 4.1.1.6	8 bit 4.1.1.7	5 bit 4.1.1.8	3 bit 4.1.1.9	11 bit 4.1.1.10	21 bit 4.1.1.11		
Byte 8			Byte 7		Byte 6	Byte 5		Byte 4	Byte 3	Byte 2	Byte 1

**Table 17 NAME Fields**

The Manufacturer Code and the Identity Number is not changeable by the user.

For programming the NAME the MH CAN J1939 Standard Sensor uses the Destination Specific Proprietary Configurable Message 1.

<b>Destination Specific Proprietary Configurable Message 1</b>	
Transmission rate:	As needed
Data length	8 bytes
Data page	0
PDU format	177
PDU specific	DA (Destination Address)
Default priority	6
Parameter Group Number	45312 (00B100) <sub>16</sub>
Source Address	0-253

**Table 18 Destination Specific Proprietary Configurable Message 1 Specification**

Destination Specific Proprietary Configurable Message 1	
Byte D0 Bits 8-1	MTS Signature 'M'
Byte D1 Bits 8-1	MTS Signature 'T'
Byte D2 Bits 8-1	MTS Signature 'S'
Byte D3 Bits 8-1	MTS Signature 'NUL'
Byte D4 Bits 8-4 Bits 3-1	Function Instance ECU Instance
Byte D5 Bits 8-1	Function
Byte D6 Bits 8-2 Bit 1	Vehicle System Reserved (don't care)
Byte D7 Bit 8 Bits 7-5 Bits 4-1	Arbitrary Address Capable (don't care) Industry Group Vehicle System Instance

**Table 19 Layout of the Destination Specific Proprietary Configurable Message 1**

The MH CAN J1939 Standard Sensor is not Arbitrary Address Capable, so this bit is don't care.

**Note:** The new NAME of the MH CAN J1939 Standard Sensor gets immediately active. The new NAME is stored in the non-volatile memory of the MH CAN J1939 Standard Sensor, so with the next Power On the MH CAN J1939 Standard Sensor uses the new NAME.

An Address Claimed message is send, after successful programming.

**Example:**

COB-ID	Rx/Tx	DLC	Data							
			D0	D1	D2	D3	D4	D5	D6	D7
0x18B1SAMA	Rx	8	0x4D	0x54	0x53	0x00	0x01	0x8F	0x06	0x40

**Figure 9 Programming NAME**

**SA** – MH CAN J1939 Standard Sensor Source Address

**MA** – Masters Source Address (all values possible except the own Source Address **SA**)

## 9.2 Configuration Transmission Repetition Rates (Update Rates)

The Transmission rate of the Data Record message the MH CAN J1939 Standard Sensor can be different depending upon the application.

For programming the Transmission rate the MH CAN J1939 Standard Sensor uses the Destination Specific Proprietarily Configurable Message 2.

The Transmission rate can be in the range of 0-65635 in ms.

Destination Specific Proprietarily Configurable Message 2	
Transmission rate:	As needed
Data length	8 bytes
Data page	0
PDU format	178
PDU specific	DA (Destination Address)
Default priority	6
Parameter Group Number	45568 (00B200) <sub>16</sub>
Source Address	0-253

**Table 20 Destination Specific Proprietarily Configurable Message 2 Specification**

Destination Specific Proprietarily Configurable Message 2	
Byte D0 Bits 8-1	MTS Signature 'M'
Byte D1 Bits 8-1	MTS Signature 'T'
Byte D2 Bits 8-1	MTS Signature 'S'
Byte D3 Bits 8-1	MTS Signature 'NUL'
Byte D4 Bits 8-1	New Transmission rate low byte
Byte D5 Bits 8-1	New Transmission rate high byte
Byte D6 Bits 8-1	Don't care
Byte D7 Bits 8-1	Don't care

**Table 21 Layout of the Destination Specific Proprietarily Configurable Message 2**

**Note:** The new Transmission rate of the MH CAN J1939 Standard Sensor gets immediately active. The new Transmission rate is stored in the non-volatile memory of the MH CAN J1939 Standard Sensor, so with the next Power On the MH CAN J1939 Standard Sensor uses the new Transmission rate.

### Example:

Programming Transmission rate = 100ms

COB-ID	Rx/Tx	DLC	Data							
			D0	D1	D2	D3	D4	D5	D6	D7
0x18B2SAMA	Rx	8	0x4D	0x54	0x53	0x00	0x64	0x00	0x00	0x00

**Figure 10 Programming Transmission rate**

**SA** – MH CAN J1939 Standard Sensor Source Address

**MA** – Masters Source Address (all values possible except the own Source Address **SA**)

### 9.3 Configuration Data Record Parameter Group Number

For the Data Record message the 7.3

Parameter Group Number Proprietary B is used.

Depending upon the application a different PGN in the range of 65280 to 65535 can be used for the Data Record message.

Destination Specific Proprietary Configurable Message 3	
Transmission rate:	As needed
Data length	8 bytes
Data page	0
PDU format	179
PDU specific	DA (Destination Address)
Default priority	6
Parameter Group Number	45824 (00B300) <sub>16</sub>
Source Address	0-253

**Table 22 Destination Specific Proprietary Configurable Message 3 Specification**

Destination Specific Proprietary Configurable Message 3	
Byte D0 Bits 8-1	MTS Signature 'M'
Byte D1 Bits 8-1	MTS Signature 'T'
Byte D2 Bits 8-1	MTS Signature 'S'
Byte D3 Bits 8-1	MTS Signature 'NUL'
Byte D4 Bits 8-1	New PGN low byte
Byte D5 Bits 8-1	New PGN high byte (always FF <sub>16</sub> )
Byte D6 Bits 8-1	Don't care
Byte D7 Bits 8-1	Don't care

**Table 23 Layout of the Destination Specific Proprietary Configurable Message 3**

**Note:** The new Data Record PGN of the MH CAN J1939 Standard Sensor gets immediately active. The new Data Record PGN is stored in the non-volatile memory of the MH CAN J1939 Standard Sensor, so with the next Power On the MH CAN J1939 Standard Sensor uses the new Data Record PGN .

**Example:**

Programming Data Record PGN = 65283 (FF03<sub>16</sub>)

COB-ID	Rx/Tx	DLC	Data							
			D0	D1	D2	D3	D4	D5	D6	D7
0x18B3SAMA	Rx	8	0x4D	0x54	0x53	0x00	0x03	0xFF	0x00	0x00

**Figure 11 Programming Data Record PGN**

**SA** – MH CAN J1939 Standard Sensor Source Address

**MA** – Masters Source Address (all values possible except the own Source Address **SA**)

## 10 J1939-71 Application Layer

The J1939-71 Application Layer describes and defines the Parameter Group Numbers and Suspect Parameter Numbers. For the MH CAN J1939 Standard Sensor only the Software Identification and Component Identification are implemented. For the Data Record information there is no corresponding Application specific Suspect Parameter.

### 10.1 Software Identification

The actual firmware version of the MH CAN J1939 Standard Sensor can be read with Request command using the Software Identification Parameter Group Number.

Software Identification	
Transmission rate:	As needed
Data length	8 bytes
Data page	0
PDU format	254
PDU specific	218
Default priority	6
Parameter Group Number	65242 (FEDA00) <sub>16</sub>
Source Address	0-253

**Table 24 Software Identification Specification**

Software Identification for MTS	
Byte D0 Bits 8-1	4
Byte D1 Bits 8-1	0x62
Byte D2 Bits 8-1	0x51
Byte D3 Bits 8-1	0x12
Byte D4 Bits 8-1	Major Software version Number
Byte D5 Bits 8-1	0
Byte D6 Bits 8-1	0
Byte D7 Bits 8-1	0

**Table 25 Layout of the MTS Software Identification Message**

#### Example:

Request Software Identification

COB-ID	Rx/Tx	DLC	Data							
			D0	D1	D2	D3	D4	D5	D6	D7
0x18EASAMA	Rx	3	0xDA	0xFE	0x00	-	-	-	-	-

Software Identification

COB-ID	Rx/Tx	DLC	Data							
			D0	D1	D2	D3	D4	D5	D6	D7
0x18FEDASA	Tx	8	0x04	0x62	0x51	0x12	Major SW Version	0x00	0x00	0x00

**Figure 12 Request Software Identification Sequence**

**SA** – MH CAN J1939 Standard Sensor Source Address

**MA** – Masters Source Address (all values possible except the own Source Address **SA**)

## 10.2 Component Identification

The actual Serial number of the MH CAN J1939 Standard Sensor can be read with Request command using the Component Identification Parameter Group Number.

Component Identification	
Transmission rate:	As needed
Data length	8 bytes
Data page	0
PDU format	254
PDU specific	235
Default priority	6
Parameter Group Number	65259 (FEEB00) <sub>16</sub>
Source Address	0-253

**Table 26 Component Identification Specification**

Component Identification for MTS	
Byte D0 Bits 8-1	0x2A
Byte D1 Bits 8-1	0x2A
Byte D2 Bits 8-1	Serial Number low-byte
Byte D3 Bits 8-1	Serial Number mid-byte
Byte D4 Bits 8-1	Serial Number mid-byte
Byte D5 Bits 8-1	Serial Number high-byte
Byte D6 Bits 8-1	0x2A
Byte D7 Bits 8-1	0x2A

**Table 27 Layout of the MTS Component Identification Message**

### Example:

Request Component Identification

COB-ID	Rx/Tx	DLC	Data							
			D0	D1	D2	D3	D4	D5	D6	D7
0x18EASAMA	Rx	3	0xEB	0xFE	0x00	-	-	-	-	-

Component Identification

COB-ID	Rx/Tx	DLC	Data							
			D0	D1	D2	D3	D4	D5	D6	D7
0x18FEEBSA	Tx	8	0x2A	0x2A	Serial Low	Serial Mid	Serial Mid	Serial High	0x2A	0x2A

**Figure 13 Request Component Identification Sequence**

**SA** – MH CAN J1939 Standard Sensor Source Address

**MA** – Masters Source Address (all values possible except the own Source Address **SA**)



### 10.3 Parameter Information

In the J1939-71 Application Layer there is a definition of so called SLOTS (Scaling, Limit, Offset, and Transfer Function) which can be used when parameters are added to J1939. This permits data consistency to be maintained as much as possible between parameters of a given type (temperature, pressure, speed, etc.). Each SLOT is intended to provide a range and resolution suitable for most parameters within a given type. When necessary, a different scaling factor or offset can be used.

For the Data Record message the following SLOTS can be used:

**Position:**

SLOT Name	Slot Type	Units	Scaling	Range	Offset	Length
SAEds04	Distance	m	0.1 mm/bit	0 to 6,425.5 mm	0 mm	2 bytes

**Velocity:**

SLOT Name	Slot Type	Units	Scaling	Range	Offset	Length
SAEv01	Velocity, linear	m/s	0.001 m/s per bit	0 to 64.255 m/s	0 m/s	2 bytes

For further information see 12

Data Record Message.

**Note:** The other information in the Data Record message have no corresponding SLOT Number.

## 11 J1939-73 Application Layer Diagnostics

The SAE J1939-73 Application Layer Diagnostics defines functions and messages for accessing diagnostic and calibration data. There are several predefined Diagnostic Messages (DM).

**Note:** The MH CAN J1939 Standard Sensor supports only the DM13 Stop Start Broadcast.

### 11.1 Stop Start Broadcast (DM13)

This message is used to stop or to start the broadcast messages, like the MH CAN J1939 Standard Sensor Data Record message.

Stop Start Broadcast DM13	
Transmission rate:	As needed
Data length	8 bytes
Data page	0
PDU format	223
PDU specific	DA (Destination Address) or Global Address
Default priority	6
Parameter Group Number	57088 (00DF00 <sub>16</sub> )
Source Address	0-253

**Table 28 Stop Start Message Specification**

Component Identification for MTS	
Byte D0 Bits 8-7	Current Data Link
Bits 6-5	J1587
Bits 4-3	J1922
Bits 2-1	J1939 Network #1, Primary vehicle network
Byte D1 Bits 8-7	J1939 Network #2
Bits 6-5	ISO 9141
Bits 4-3	J1850
Bits 2-1	Other, Manufacture Specified Port
Byte D2 Bits 8-7	J1939 Network #3
Bits 6-5	SAE Reserved
Bits 4-3	SAE Reserved
Bits 2-1	SAE Reserved
Byte D3 Bits 8-5	Hold Signal
Bits 4-1	Suspend Signal
Byte D4 Bits 8-1	Suspend Duration
Byte D5 Bits 8-1	Suspend Duration
Byte D6 Bits 8-1	SAE Reserved
Byte D7 Bits 8-1	SAE Reserved

**Table 29 Layout of the Stop Start Message**

The sensor is assigned to the J1939 Network #1, Primary vehicle network or Current Data link. The Stop Broadcast timeout is normally 6 sec. (see J1973 5.7.13) but can be suspended with 'Hold Signal'. After a Stop Broadcast time the MH CAN J1939 Standard Sensor starts the Data Record message transmission automatically.

After a Power On Reset the MH CAN J1939 Standard Sensor is in the Start Broadcast state.

For each of the 2-bit fields in the Stop Start Broadcast command, they are interpreted as follows:

Bits	Information
00	Stop Broadcast
01	Start Broadcast
10	Reserved
11	Don' care / take no action

**Table 30 DM13 Bit definitions**

**Example:**

Stop Broadcast Current Data Link

COB-ID	Rx/Tx	DLC	Data							
			D0	D1	D2	D3	D4	D5	D6	D7
0x18DFSAMA	Rx	8	0x3F	0xFF	0xFF	0xFF	0xFF	0xFF	0xFF	0xFF

**Figure 14 Stop Broadcast Current Data Link**

Start Broadcast after Stop Broadcast Current Data Link

COB-ID	Rx/Tx	DLC	Data							
			D0	D1	D2	D3	D4	D5	D6	D7
0x18DFSAMA	Rx	8	0x7F	0xFF	0xFF	0xFF	0xFF	0xFF	0xFF	0xFF

**Figure 15 Start Broadcast Current Data Link**

Stop Broadcast J1939 Network #1

COB-ID	Rx/Tx	DLC	Data							
			D0	D1	D2	D3	D4	D5	D6	D7
0x18DFSAMA	Rx	8	0xFC	0xFF	0xFF	0xFF	0xFF	0xFF	0xFF	0xFF

**Figure 16 Stop Broadcast J1939 Network #1**

Start Broadcast after Stop Broadcast J1939 Network #1

COB-ID	Rx/Tx	DLC	Data							
			D0	D1	D2	D3	D4	D5	D6	D7
0x18DFSAMA	Rx	8	0xFD	0xFF	0xFF	0xFF	0xFF	0xFF	0xFF	0xFF

**Figure 17 Start Broadcast J1939 Network #1**

**SA** – MH CAN J1939 Standard Sensor Source Address or Global Address

**MA** – Masters Source Address (all values possible except the own Source Address **SA**)

The **Hold Signal** is an indicator to all devices to remain in the current Stop Broadcast state. A device requesting stop broadcast must send the hold signal every 5 seconds. If the message is not received for 6 seconds all applicable nodes revert to their normal state.

Bit States for bits 8-5	Devices to take action
0000	All devices
0001	Devices whose broadcast state has been modified
0010 to 1110	Reserved
1111	Not available

**Table 31 DM13 Hold Signal Bit definitions**

**Note:** The MH CAN J1939 Standard Sensor holds the Stop Broadcast state every time the Hold Signal bits are 0001 regardless if the broadcast state has changed or not.

**Example:**

DM13 Hold signal (same for Current Data Link and J939 Network #1)

COB-ID	Rx/Tx	DLC	Data							
			D0	D1	D2	D3	D4	D5	D6	D7
0x18DFSAMA	Rx	8	0xFF	0xFF	0xFF	0x0F	0xFF	0xFF	0xFF	0xFF

**Figure 18 DM13 Hold signal**

**SA** – MH CAN J1939 Standard Sensor Source Address or Global Address

**MA** – Masters Source Address (all values possible except the own Source Address **SA**)

**Note:** The MH CAN J1939 Standard Sensor does not support the Suspend Signal and Suspend Duration of the DM13 Stop Start Broadcast.

## 12 Data Record Message

The Data Record message contains the position and velocity information of the MH CAN J1939 Standard Sensor. It also has status, Error code and limit information.

The transmission of the Data Record message starts automatically after Power On.

The transmission rate of the Data Record message can be changed by using the 9.2 Configuration Transmission Repetition Rates (Update Rates). The default transmission rate is 20ms.

Parameter Group Number Data Record	
Transmission rate:	Default 20ms Data range 0-65535ms
Data length	8 bytes
Data page	0
PDU format	Default 255
PDU specific	Group Extension
Default priority	Default 6
Parameter Group Number	Default 65535 Data Range 65280 to 65535 (00FF00 <sub>16</sub> to 00FFFF <sub>16</sub> )
Source Address	0 to 253

**Table 32 Data Record PGN Specification**

Data Field	
Byte D0 Bits 8-1	Least significant byte of the Position
Byte D1 Bits 8-1	Most significant byte of the Position
Byte D2 Bits 8-1	Least significant byte of the Velocity
Byte D3 Bits 8-1	Most significant byte of the Velocity
Byte D4 Bits 8-1	Status
Byte D5 Bits 8-1	Error Code
Byte D6 Bits 8-1	Limit Status
Byte D7 Bits 8-1	0xFF

**Table 33 MH J1939 J01 Data Record message Data Field**

COB-ID	Rx/Tx	DLC	Data							
			D0	D1	D2	D3	D4	D5	D6	D7
0x18PFPSA	Tx	8	Position Low- byte	Position High- byte	Velocity Low- byte	Velocity High- byte	Senor Status	Error Code	Limit Status	0xFF

**Figure 19 Data Record message**

**SA** – MH CAN J1939 Standard Sensor Source Address

**PF** – PDU Format is fixed to 255 (FF<sub>16</sub>)

**PS** – PDU Specific can be 0-255 (0<sub>16</sub> – FF<sub>16</sub>)  
(see 9.3 Configuration Data Record Parameter Group Number)

**Position:**

The default resolution is 100 $\mu$ m.

Position data in [0.1mm] Intel format as UNSIGNED16

Data byte0	Data byte1
Position data LSB	Position data MSB

**Velocity:**

The resolution of the velocity information is fixed to 1mm/s.

VD – Velocity data in [1mm/s] Intel format as UNSIGNED16

Data byte2	Data byte3
Velocity data LSB	Velocity data MSB

SS – Sensor Status

Data byte4
------------

Sensor Status

- Sensor Status = **0x00 Normal**
- = **0x01 Data warning** (for additional error information see EC Error code)
- = **0x11 Error** (for additional error information see EC Error code)

Warning is set under the following conditions:

- The Position value buffer for the velocity calculation has not 100 consecutively valid Position values. In the Error code the Range bit is set.
- The Position value is below the Low Limit value.  
The corresponding bit in the Limit register is set.
- The Position value is above the High Limit value.  
The corresponding bit in the Limit register is set.
- More than one magnet detected during the last measuring cycle.  
The Position and Velocity value is calculated from the first detected magnet.  
The Multiple Magnet Error bit is set in the Error Code register.

The Position and the Velocity value are still transmitted in this state.

Error is set under the following conditions:

- **Controller Error.** The internal test routines reported an error.  
This can be Register, RAM, CPU, Measuring Cycle, Start Impulse length, Stop counter or program flow error.  
The Controller Error bit is set in the Error Code register.
- **Data Flash Error.** The internal test routine at Power up reported a checksum error of the MH CAN J1939 Standard Sensor parameters stored in the Data Flash.  
The Data Flash Error bit is set in the Error Code register.
- **Position value is out of the physical possible value range.**  
The Range Error bit is set in the Error Code register.
- **The Position value is below the Working Area Low Limit**  
The corresponding bit in the Limit register is set.
- **The Position value is above the Working Area High Limit**  
The corresponding bit in the Limit register is set.
- **No Magnet is detected.**  
The No Magnet Error bit is set in the Error Code register.

The Position and the Velocity value is set to 65535 ( $FFFF_{16}$ ).

EC – Error Code

**Data byte5**

Error Code

The Temperature bit is set when the internal Temperature of the MH CAN J1939 Standard Sensors Microcontroller exceeds 120°C.

The definition of the Sensor Error Code Register is as follows:

D7	D6	D5	D4	D3	D2	D1	D0
0	0	MM	NM	T	RE	CE	DE

**Figure 20 Sensor Error Code Register definition**

DE:	Data Flash Error	0 = no Error 1 = The CRC check of Data Flash parameter memory failed
CE:	Controller Error	0 = no Error 1 = The internal test routines detects an Error.
RE:	Range Error	0 = no Error 1 = the calculated Position is out of range when also the Position and velocity value is set to 0xFFFF 1 = the velocity value maybe not correct
T:	Temperature $\mu C$	0 = $T < \text{Max Temperature}$ 1 = $T > \text{Max Temperature}$
NM:	No Magnet Error	0 = one magnet detected 1 = no magnet detected
MM:	Multiple Magnet Error	0 = one magnet detected 1 = more than one magnet detected

LS – Limit Status

**Data byte6**

Limit Status

The definition of the Limit Status Register is as follows:

D7	D6	D5	D4	D3	D2	D1	D0
0	0	0	0	WAHL	HL	WALL	LL

**Figure 21 Sensor Limit Status Register definition**

<b>LL: Low Limit</b>	<b>Position value at measuring zero Position</b> 0 = Position value above Low Limit 1 = Position value below Low Limit
<b>WALL: Working Area Low Limit</b>	<b>Position value at measuring zero Position – 5mm</b> 0 = Position value above Working Area Low Limit 1 = Position value below Working Area Low Limit
<b>HL: High Limit</b>	<b>Position value at measuring end Position</b> 0 = Position value below High Limit 1 = Position value above High Limit
<b>WAHL: Working Area High Limit</b>	<b>Position value at measuring end Position + 5mm</b> 0 = Position value below Working Area High Limit 1 = Position value above Working Area High Limit

## 13 Literature

- # 1 SAE J1939-21 – Data Link Layer
- # 2 SAE J1939-71 – Application Layer
- # 3 SAE J1939-73 – Application Layer - Diagnostics
- # 4 SAE J1939-74 – Application - Configurable Messaging
- # 5 SAE J1939-81 – Network Management
- # A Comprehensive Guide to J1939 by Wilfried Voss



**Document Part Number: 901491 Revision A (EN)**

MTS and Temposonics® are registered trademarks of MTS Systems Corporation. All other trademarks are the property of their respective owners. Printed in Germany.

Copyright © 2013 MTS Sensor Technologie GmbH & Co. KG. Alterations reserved. All rights reserved in all media. No license of any intellectual property rights is granted. The information is subject to change without notice and replaces all data sheets previously supplied. The availability of components on the market is subject to considerable fluctuation and to accelerated technical progress. Therefore we reserve the right to alter certain components of our products depending on their availability. In the event that product approbations or other circumstances related to your application do not allow a change in components, a continuous supply with unaltered components must be agreed by specific contract.



**MTS Sensor Technologie  
GmbH & Co. KG**  
Auf dem Schüffel 9  
58513 Lüdenscheid, Germany  
Tel. + 49-23 51-95 87 0  
Fax + 49-23 51-5 64 91  
E-Mail: [info@mtssensor.de](mailto:info@mtssensor.de)  
[www.mtssensor.de](http://www.mtssensor.de)

**MTS Systems Corporation**  
Sensors Division  
3001 Sheldon Drive  
Cary, N.C. 27513, USA  
Tel. + 1-919-677-0100  
Fax + 1-919-677-0200  
E-Mail: [sensorsinfo@mts.com](mailto:sensorsinfo@mts.com)  
[www.mtssensors.com](http://www.mtssensors.com)

**MTS Sensors Technology Corp.**  
737 Aihara-cho,  
Machida-shi, Japan  
Tel. + 81-42-775-3838  
Fax + 81-42-775-5516  
E-Mail: [info@mtssensor.co.jp](mailto:info@mtssensor.co.jp)  
[www.mtssensor.co.jp](http://www.mtssensor.co.jp)