

Temposonics®

Magnetostrictive Linear Position Sensors



Sensor with Ex approval

ET Analog ATEX / IECEx / CEC / NEC Certified
Operation Manual



Table of contents

1. Introduction	3
1.1 Purpose and use of this manual	3
1.2 Used symbols and warnings	3
2. Safety instructions	3
2.1 Intended use	3
2.2 Foreseeable misuse	3
2.3 Installation, commissioning and operation	4
2.4 Safety instructions for use in explosion-hazardous areas	5
2.5 Warranty	5
2.6 Return	5
3. Identification	6
3.1 Order code Temposonics® ET	6
3.2 Nameplate (example)	7
3.3 Approvals	7
3.4 Scope of delivery	7
4. Product description and commissioning	7
4.1 Functionality and system design	7
4.2 Styles and installation of Temposonics® ET	8
4.3 Magnet installation	10
4.4 Electrical connection	12
4.5 Frequently ordered accessories	13
5. Operation	15
5.1 Getting started	15
5.2 Programming and configuration	15
6. Maintenance and troubleshooting	22
6.1 Error conditions, troubleshooting	22
6.2 Maintenance	22
6.3 Repair	22
6.4 List of spare parts	22
6.5 Transport and storage	22
7. Removal from service / dismantling	22
8. Technical data of Temposonics® ET	23
9. Appendix	25
10. Declaration of conformity	26

1. Introduction

1.1 Purpose and use of this manual

Before starting the operation of Temposonics® position sensors read this documentation thoroughly and follow the safety information. Keep the manual for future reference!

The content of this technical documentation and of its appendix is intended to provide information on mounting, installation and commissioning by qualified automation personnel ¹ or instructed service technicians who are familiar with the project planning and dealing with Temposonics® sensors.

1.2 Used symbols and warnings

Warnings are intended for your personal safety and for avoidance of damage to the described product or connected devices. In this documentation, safety information and warnings to avoid danger that might affect the life and health of operating as well as service personnel or cause material damage are highlighted by the preceding pictogram, which is defined below.

Symbol	Meaning
NOTICE	This symbol is used to point to situations that may lead to material damage, but not to personal injury.

2. Safety instructions

2.1 Intended use

This product may be used only for the applications defined under item 1 to item 4 and only in conjunction with the third-party devices and components recommended or approved by MTS Sensors. As a prerequisite of proper and safe operation, the product requires correct transport, storage, mounting and commissioning and must be operated with utmost care.

1. The sensor systems of all Temposonics® series are intended exclusively for measurement tasks encountered in industrial, commercial and laboratory applications. The sensors are considered as system accessories and must be connected to suitable evaluation electronics, e.g. a PLC, IPC, indicator or other electronic control unit.
2. The sensor's surface temperature class is T4.
3. The ATEX, IECEx, NEC and CEC certificates have to be taken into account, including any special conditions defined therein, as well as chapter "2.3 Installation, commissioning and operation" on page 4.

^{1/} The term qualified technical personnel characterizes persons who:

- are familiar with the safety concepts of automation technology applicable to the particular project
- are competent in the field of electromagnetic compatibility (EMC)

4. The position sensor may be used in hazardous areas according to Fig. 36. Any use of this product outside of these approved areas will void the warranty and all manufacturer's product responsibilities and liabilities. For non-hazardous areas MTS Sensors recommends to use the version N (not approved).

Zone	Explosion group
Zone 2 (Gas-Ex, category 3G, EPL Gc)	IIA, IIB and IIC
Zone 22 (Dust-Ex, category 3D, EPL Dc)	IIIA, IIIB and IIIC

Class	Group
Class I (Gas, Division 2)	A, B, C, D
Class II / III (Dust, Division 2)	F, G

2.2 Forseeable misuse

Forseeable misuse	Consequence
Lead compensating currents through the enclosure	The sensor will be damaged
Wrong sensor connection	The sensor will not work properly or will be destroyed
Operate the sensor out of the operating temperature range	No signal output The sensor can be damaged
Power supply is out of the defined range	Signal output is wrong / no signal output / the sensor will be damaged
Position measurement is influenced by an external magnetic field	Signal output is wrong
Cables are damaged	Short circuit – the sensor can be destroyed / sensor does not respond
Spacers are missing / are installed in a wrong order	Error in position measurement
Wrong connection of ground / shield	Signal output is disturbed The electronics can be damaged
Use of a magnet that is not certified by MTS Sensors	Error in position measurement
Output 2 is connected to ground low-impedance, output 1 is connected high-impedance	The sensor is in programming mode – The sensor delivers faulty position values

- have received adequate training for commissioning and service operations
- are familiar with the operation of the device and know the information required for correct operation provided in the product documentation

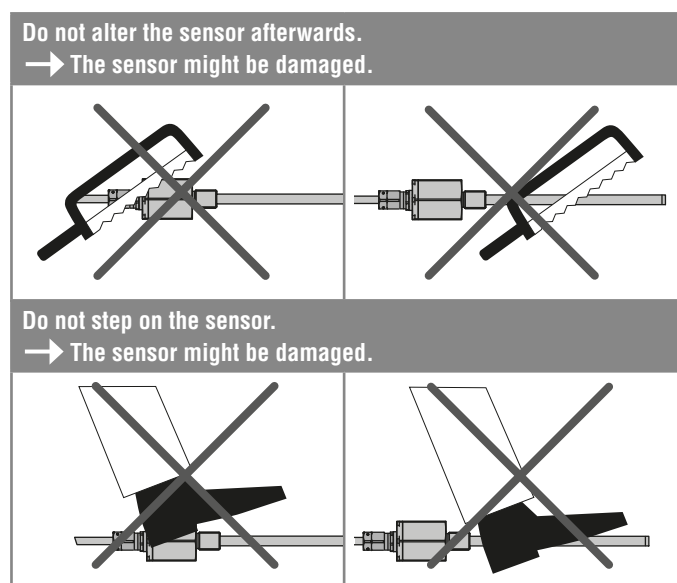

2.3 Installation, commissioning and operation

The position sensors must be used only in technically safe condition. To maintain this condition and to ensure safe operation, installation, connection and service, work may be performed only by qualified technical personnel, according to IEC 60079-14, IEC 60079-17, TRBS 1203, Canadian Electrical Code (CEC), National Electrical Code (NEC) and local regulations.

If danger of injury to persons or of damage to operating equipment is caused by sensor failure or malfunction, additional safety measures such as plausibility checks, limit switches, EMERGENCY STOP systems, protective devices etc. are required. In the event of trouble, shut down the sensor and protect it against accidental operation.

Safety instructions for commissioning

To maintain the sensor's operability, it is mandatory to follow the instructions given below.

1. Follow the specifications given in the technical data.
2. Ensure that equipment and associated components used in a hazardous environment are selected and installed in compliance with regulations governing the geographical location and facility. Only install equipment that complies with the types of protection relevant to the applicable Zones and Categories.
3. In explosive atmospheres use only such auxiliary components that meet all requirements of the local and national standards.
4. The potential equalisation of the system has to be established according to the regulations of erection applicable in the respective country of use (VDE 0100, part 540; IEC 364-5-54).
5. Sensors from MTS Sensors are approved only for the intended use in industrial environments (see chapter "2.1 Intended use" on page 3). Contact the manufacturer for advice, if aggressive substances are present in the sensor environment.
6. Measures for lightning protection have to be taken by the user.
7. The user is responsible for the mechanical protection of the sensor.

8. The cable gland of the sensor must be protected against any external impact energy exceeding 4 J. The maximum thermal load of the cables must be taken into account.
9. The user is responsible for meeting all safety conditions as outlined by:
 - Installation instructions
 - Local prevailing standards and regulations
10. Any parts of the equipment which got stuck (e.g. by frost or corrosion) may not be removed by force if potentially explosive atmosphere is present.
11. The formation of ice on the equipment has to be prevented.
12. It is not allowed to open the sensor.
13. The connecting cable has to be either led out of the hazardous area uncut or wired to outlets which comply with the type of protection required locally.
14. The surface temperatures of equipment parts must be kept clearly below the ignition temperature of the foreseeable air / dust mixtures in order to prevent the ignition of suspended dust.

How to ensure safe commissioning

1. Protect the sensor against mechanical damage during installation and operation.
2. Do not use damaged products and secure them against unintentional commissioning. Mark damaged products as being defective.
3. Prevent electrostatic charges.
4. Do not use the sensor in cathodic systems for corrosion protection. Do not led parasitic currents via the construction.
5. Switch off the supply voltage prior to disconnecting or connecting the equipment.
6. Connect the sensor very carefully and pay attention to the polarity of connections, power supply as well as to the shape and duration of control pulses.
7. Use only approved power supplies.
8. Ensure that the specified permissible limit values of the sensor for supply voltage, environmental conditions, etc. are met.
9. Make sure that:
 - the sensor and associated components were installed according to the instructions
 - the sensor enclosure is clean
 - the magnet does not grind on the rod. This could cause damage to the magnet and the sensor rod. If there is contact between the moving magnet including the magnet holder and the sensor rod, make sure that the maximal speed of the moving magnet is less or equal 1 m/s.
10. Ground the sensor via the ground lug. Both the sensor and the moving magnet including magnet holder must be connected to protective ground (PE) to avoid electrostatic discharge (ESD).
11. Before applying power, ensure that nobody's safety is jeopardized by starting machines.
12. Check the function of the sensor regularly and provide documentation of the checks.
(see chapter "6.2 Maintenance" on page 22).

2.4 Safety instructions for use in explosion-hazardous areas

The sensor has been designed for operation inside explosion-hazardous areas. It has been tested and left the factory in a condition in which it is safe to operate. Relevant regulations and European standards as well as Canadian and North American standards have been observed. According to Ex marking (see chapter “2.1 Intended use” on page 3) and the ATEX, IECEx, NEC and CEC certificates (attached to this document), the sensor is approved only for operation in defined hazardous areas.

2.5 Warranty

MTS Sensors grants a warranty period for the Temposonics® position sensors and supplied accessories relating to material defects and faults that occur despite correct use in accordance with the intended application². The MTS Sensors obligation is limited to repair or replacement of any defective part of the unit. No warranty can be provided for defects that are due to improper use or above average stress of the product, as well as for wear parts. Under no circumstances will MTS Sensors accept liability in the event of offense against the warranty rules, no matter if these have been assured or expected, even in case of fault or negligence of the company. MTS Sensors explicitly excludes any further warranties. Neither the company's representatives, agents, dealers nor employees are authorized to increase or change the scope of warranty.

2.6 Return

For diagnostic purposes, the sensor can be returned to MTS Sensors. Any shipment cost is the responsibility of the sender². For a corresponding form, see chapter “9. Appendix” on page 25.

^{2/} See also applicable MTS Sensors terms of sales and delivery on www.mtssensors.com

3. Identification

3.1 Order code Temposonics® ET

1	2	3	4	5	6	7	8	9	10	11	12	13	14	15	16
E	T										1				
a		b	c					d			e	f	g		

a	Sensor model
E T	Rod

b	Design
ET rod-style sensor with housing and sensor rod material stainless steel 1.4404 (AISI 316L)	
F	Threaded flange ¾"-16 UNF-3A
W	Threaded flange M18×1.5-6g
ET rod-style sensor with housing material stainless steel 1.4305 (AISI 303) and sensor rod material stainless steel 1.4306 (AISI 304L)	
M	Threaded flange M18×1.5-6g
S	Threaded flange ¾"-16 UNF-3A

c	Stroke length
X X X X M	0050...3000 mm
Standard stroke length (mm)*	
	50 ... 500 mm
	500 ... 750 mm
	750...1000 mm
	1000...2500 mm
	2500...3000 mm
X X X X U	002.0...118.0 in.
Standard stroke length (in.)*	
	2 ... 20 in.
	20 ... 30 in.
	30 ... 40 in.
	40...100 in.
	100...116 in.

d	Connection type
T X X	T01...T10 (1...10 m) ³ XX m Teflon® cable (part no. 530 112)
	T03...T33 (3...33 ft) ³ XX ft Teflon® cable (part no. 530 112)
V X X	V01...V10 (1...10 m) ³ XX m silicone cable (part no. 530 113)
	V03...V33 (3...33 ft) ³ XX ft silicone cable (part no. 530 113)

*/ Non standard stroke lengths are available; must be encoded in 5 mm / 0.1 in. increments

3/ Encode in meters if using metric stroke length. Encode in feet if using US customary stroke length

e	Operating voltage
1	+24 VDC (-15 / +20 %)

f	Version (see "Certification of Temposonics® ET (version A and E)" on page 24 for further information)
A	ATEX / IECEx / CEC / NEC
E	ATEX / IECEx / CEC / NEC with ½" NPT adapter
N	Not approved

NOTICE

Version E (section f) is only available with design (section b) »M« and »S«.

g	Output
Voltage	
1 output with 1 position magnet	
Output 1 (position magnet 1)	
V 0 1	0...10 VDC
V 1 1	10...0 VDC
2 outputs with 1 position magnet	
Output 1 (position magnet 1) + output 2 (position magnet 1)	
V 0 3	0...10 VDC 10...0 VDC
2 outputs with 2 position magnets	
Output 1 (position magnet 1) + output 2 (position magnet 2)	
V 0 2	0...10 VDC 0...10 VDC
V 1 2	10...0 VDC 10...0 VDC
Current	
1 output with 1 position magnet	
Output 1 (position magnet 1)	
A 0 1	4...20 mA
A 1 1	20...4 mA
2 outputs with 1 position magnet	
Output 1 (position magnet 1) + output 2 (position magnet 1)	
A 0 3	4...20 mA 20...4 mA
2 outputs with 2 position magnets	
Output 1 (position magnet 1) + output 2 (position magnet 2)	
A 0 2	4...20 mA 4...20 mA
A 1 2	20...4 mA 20...4 mA

NOTICE

Use magnets of the same type (e.g. 2 ring magnets with part no. 201 542-2) for multi-position measurement.

3.2 Nameplate (example)



Fig. 1: Label of sensor for use in explosion hazardous areas



Fig. 2: Label of sensor without certification for use in explosion hazardous areas

3.3 Approvals

See chapter “8. Technical data of Temposonics® ET” on page 23 f.

3.4 Scope of delivery

ET (rod sensor):

- Sensor

4. Product description and commissioning

4.1 Functionality and system design

Product designation

- Position sensor Temposonics® E-Series

Sensor model

- Temposonics® ET (rod sensor)

Stroke length

- 50...3000 mm (2...118 in.)

Output signal

- Analog

Application

Temposonics® position sensors are used for measurement and conversion of the length (position) variable in the fields of automated systems and mechanical engineering.

Principle of operation and system construction

The absolute, linear position sensors provided by MTS Sensors rely on the company's proprietary Temposonics® magnetostrictive technology, which can determine position with a high level of precision and robustness. Each Temposonics® position sensor consists of a ferromagnetic waveguide, a position magnet, a strain pulse converter and supporting electronics. The magnet, connected to the object in motion in the application, generates a magnetic field at its location on the waveguide. A short current pulse is applied to the waveguide. This creates a momentary radial magnetic field and torsional strain on the waveguide. The momentary interaction of the magnetic fields releases a torsional strain pulse that propagates the length of the waveguide. When the ultrasonic wave reaches the end of

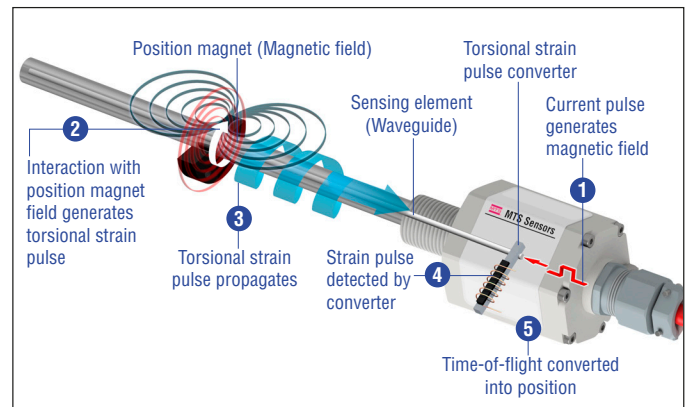

Fig. 3: Time-of-flight based magnetostrictive position sensing principle

the waveguide it is converted into an electrical signal. Since the speed of the ultrasonic wave in the waveguide is precisely known, the time required to receive the return signal can be converted into a linear position measurement with both high accuracy and repeatability.

Modular mechanical and electronic construction

- The sensor rod protects the inner sensor element.
- The sensor electronics housing, a rugged stainless steel construction, contains the complete electronic interface with active signal conditioning.
- The external position magnet is a permanent magnet. Mounted on the mobile machine part, it travels along the sensor rod and triggers the measurement through the sensor rod wall.
- The sensor can be connected directly to a control system. Its electronics generates a strictly position proportional signal output between start and end position.

4.2 Styles and installation of Temposonics® ET

ET-F / -M / -S / -W, example: Version A / N

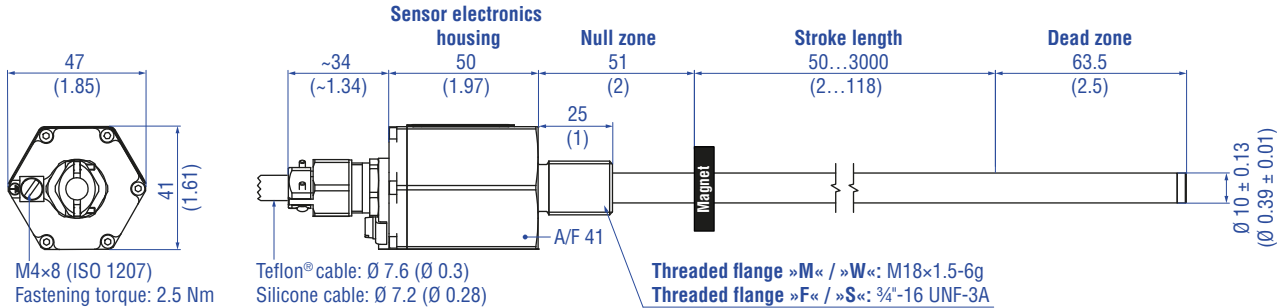

ET-F / -M / -S / -W, example: Version E

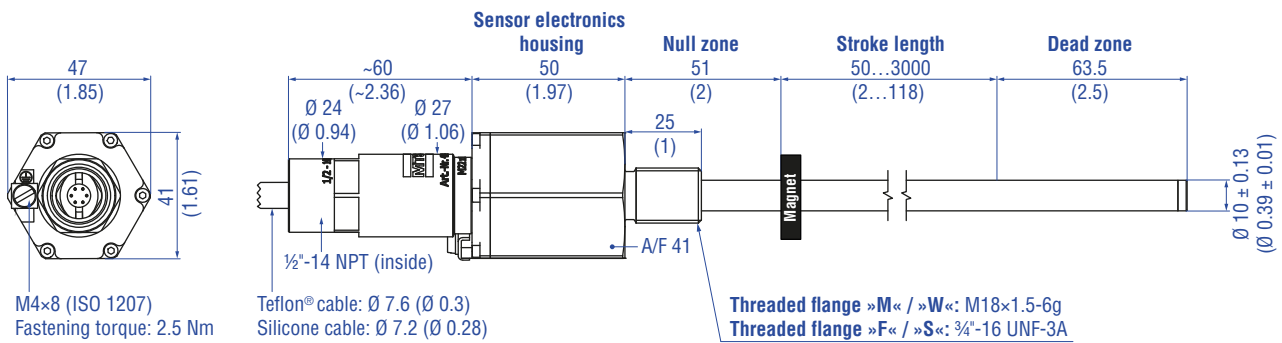

Controlling design dimensions are in millimeters and measurements in () are in inches

Fig. 4: Temposonics® ET with ring magnet

Installation of ET with threaded flange »F«, »M«, »S« & »W«

Fix the sensor rod via threaded flange M18x1.5-6g or 3/4"-16 UNF-3A.

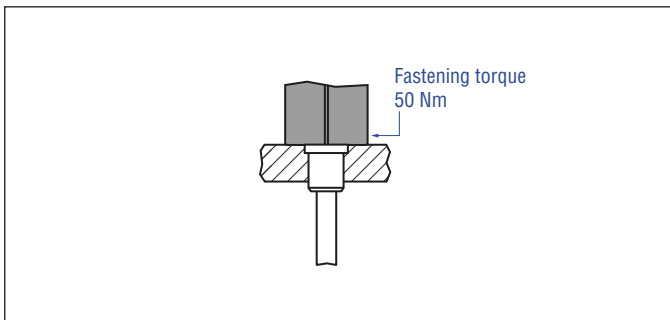

Fig. 5: Mounting example of threaded flange »F«, »M«, »S«, »W«

Installation of a rod-style sensor in a fluid cylinder

The rod-style version has been developed for direct stroke measurement in a fluid cylinder. Mount the sensor via threaded flange or a hex nut.

- Mounted on the face of the piston, the position magnet travels over the rod without touching it and indicates the exact position through the rod wall – independent of the hydraulic fluid.
- The pressure resistant sensor rod is installed into a bore in the piston rod.

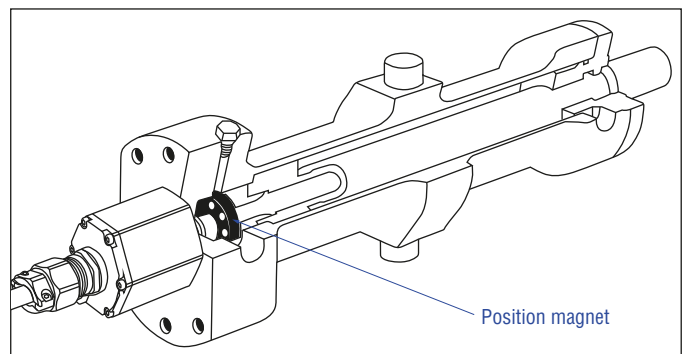

Fig. 6: Sensor in cylinder

Hydraulics sealing

There are two ways to seal the flange contact surface (Fig. 7):

1. A sealing by using an O-ring (e.g. 22.4 × 2.65 mm (0.88 × 0.1 in.), 25.07 × 2.62 mm (0.99 × 0.1 in.)) in a cylinder end cap groove.
2. A sealing by using an O-ring in the undercut.

For threaded flange (3/4"-16 UNF-3A) »F« / »S«:

O-ring 16.4 × 2.2 mm (0.65 × 0.09 in.) (part no. 560 315)

For threaded flange (M18×1.5-6g) »M« / »W«:

O-ring 15.3 × 2.2 mm (0.60 × 0.09 in.) (part no. 401 133)

In the case of threaded flange M18×1.5-6g provide a screw hole based on ISO 6149-1 (Fig. 8). See ISO 6149-1 for further information.

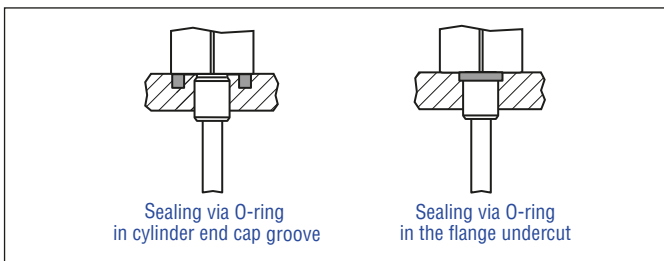

Fig. 7: Possibilities of sealing

- Note the fastening torque of 50 Nm.
- Seat the flange contact surface completely on the cylinder mounting surface.
- The cylinder manufacturer determines the pressure-resistant gasket (copper gasket, O-ring, etc.).
- The position magnet should not grind on the sensor rod.
- The piston rod drilling ($\geq \varnothing 13$ mm ($\geq \varnothing 0.51$ in.)) depends on the pressure and piston speed.
- Adhere to the information relating to operating pressure.
- Protect the sensor rod against wear.

Notice for metric threaded flanges

Thread ($d_1 \times P$)	d_2	d_3	d_4	d_5 +0.1 0	L_1 +0.4 0	L_2	L_3	L_4	Z° $\pm 1^\circ$
M18×1.5-6g	55	≥ 13	24.5	19.8	2.4	28	2	≥ 25.5	15°

All dimensions in mm

Fig. 8: Notice for metric threaded flange M18×1.5-6g based on DIN ISO 6149-1

4.3 Magnet installation

Typical use of magnets



Magnet	Benefits
 <p>Ring magnets</p>	<ul style="list-style-type: none"> • Rotationally symmetrical magnetic field
 <p>U-magnets</p>	<ul style="list-style-type: none"> • Height tolerances can be compensated

Fig. 9: Typical use of magnets

Mounting ring magnets & U-magnets

Install the magnet using non-magnetic material for mounting device, screws, spacers etc.. The magnet must not grind on the sensor rod. Alignment errors are compensated via the air gap.

- Permissible surface pressure: Max. 40 N/mm²
- Fastening torque for M4 screws: 1 Nm; use washers, if necessary
- Minimum distance between position magnet and any magnetic material has to be 15 mm (0.6 in.) (Fig. 11).
- If no other option exists and magnetic material is used, observe the specified dimensions (Fig. 11).

NOTICE

Mount ring magnets and U-magnets concentrically.
 Do not exceed the maximum acceptable gap (Fig. 10).

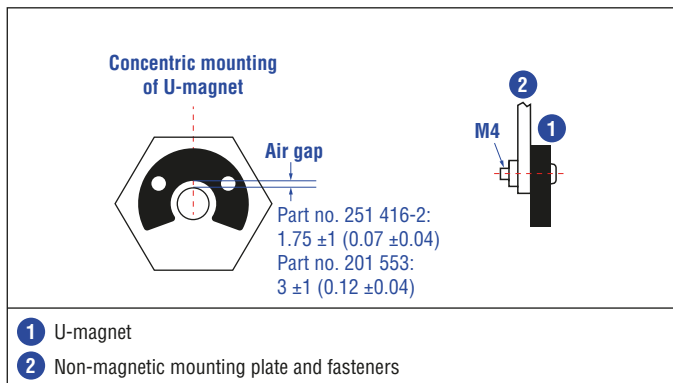

Fig. 10: Mounting of U-magnet (part no. 251 416-2 or part no. 201 553)

Magnet mounting with magnetic material

When using magnetic material the dimensions of Fig. 11 must be observed.

- A. If the position magnet aligns with the drilled piston rod
- B. If the position magnet is set further into the drilled piston rod, install another non-magnetic spacer (e.g. part no. 400 633) above the magnet.

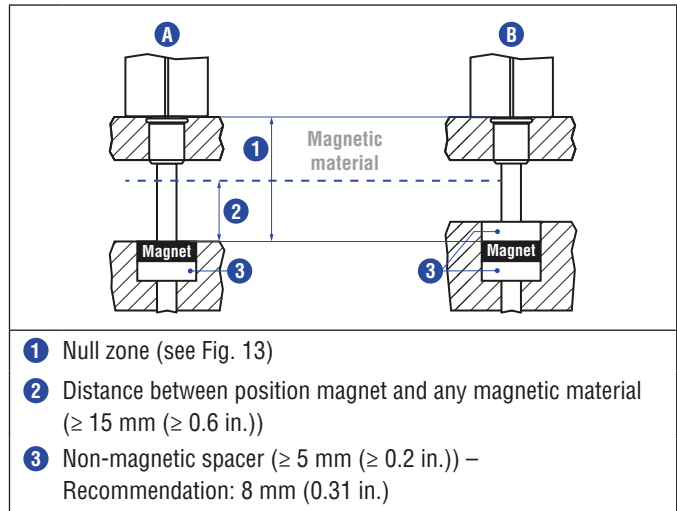

Fig. 11: Installation with magnetic material

Sensors with stroke lengths ≥ 1 meter (3.3 ft.)

Support horizontally installed sensors with a stroke length from 1 meter (3.3 ft.) mechanically at the rod end. Without the use of a support, rod and position magnet may be damaged. A false measurement result is also possible. Longer rods require evenly distributed mechanical support over the entire length (e.g. part no. 561 481). Use an U-magnet (Fig. 12) for measurement.

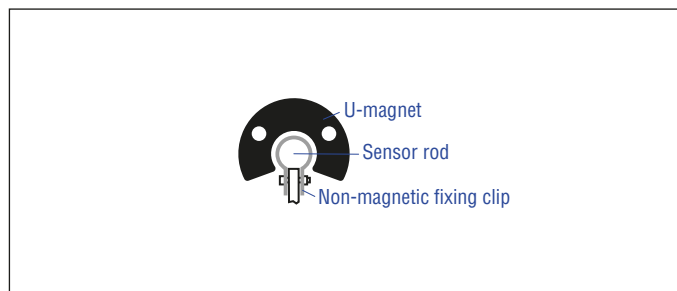

Fig. 12: Example of sensor support (part no. 561 481)

Start and end positions of the position magnets

Consider the start and end positions of the position magnets during the installation. To ensure that the entire stroke length is electrically usable, the position magnet must be mechanically mounted as follows.

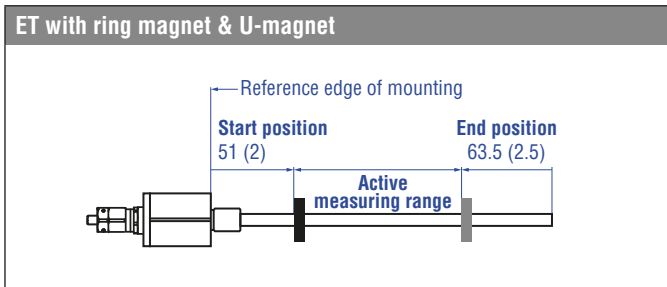

Fig. 13: Start and end positions of magnets

NOTICE

On all sensors, the areas left and right of the active stroke length are provided for null and dead zone (see “4.2 Styles and installation of Temposonics® ET” on page 8). These zones should not be used for measurement, however the active stroke length can be exceeded.

Multi-position measurement

The minimum distance between the magnets is 75 mm (3 in.).

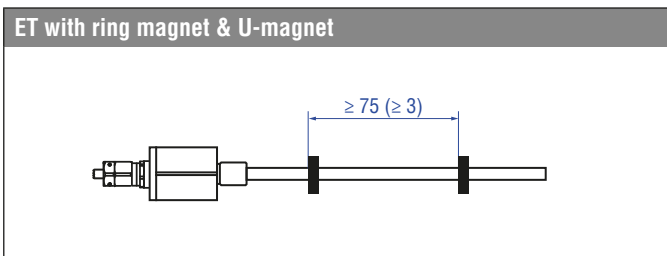

Fig. 14: Minimum distance for multi-position measurement

NOTICE

Use magnets of the same type (e.g. two ring magnets with part no. 201 542-2) for multi-position measurement.

4.4 Electrical connection

Placement of installation and cabling have decisive influence on the sensor's electromagnetic compatibility (EMC). Hence correct installation of this active electronic system and the EMC of the entire system must be ensured by using suitable metal connectors, shielded cables and grounding. Overvoltages or faulty connections can damage the sensor electronics despite protection against wrong polarity.

NOTICE

1. Do not mount the sensors in the area of strong magnetic or electric noise fields.
2. Never connect / disconnect the sensor when voltage is applied.

Instruction for connection

- Connect the shield to ground externally via the controller equipment.
- Keep control and signal leads separate from power cables and sufficiently far away from motor cables, frequency inverters, valve lines, relays, etc..
- Use only connectors with metal housing, if you use a connector. Connect the shielding to the connector housing.
- Keep all non-shielded leads as short as possible.
- Keep the earth connection as short as possible with a large cross section. Avoid ground loops.
- With potential differences between machine and electronics earth connections, no compensating currents are allowed to flow across the cable shielding.

Recommendation:

- Install potential compensating leads with large cross section.
- Use only stabilized power supplies in compliance with the specified electrical ratings.

Grounding of rod sensors

Connect the sensor electronics housing to machine ground. Ground sensor type ET version A (with ATEX / IECEx / CEC / NEC approval) via ground lug as shown in Fig. 15. Ground the sensor type ET version N (not approved) via ground lug as shown in Fig. 15 or via thread. Ground sensor type ET version E (with ATEX / IECEx / CEC / NEC approval) via ground lug as shown in Fig. 16.

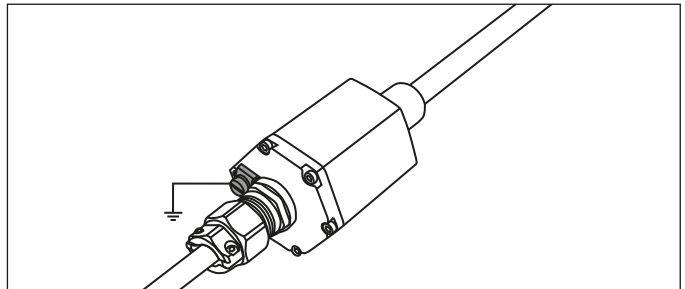

Fig. 15: Grounding via ground lug (version A, N)

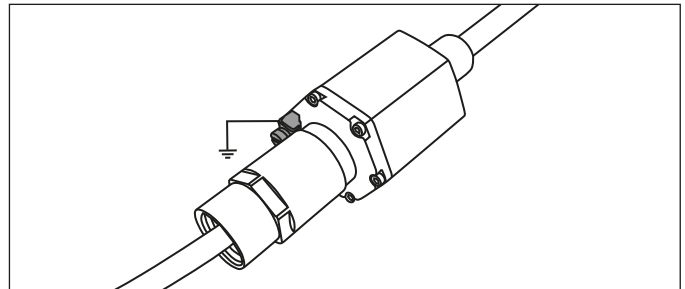

Fig. 16: Grounding via ground lug (version E)

Connector wiring

Connect the sensor directly to the controller, indicator or other evaluating systems as follows:

TXX / VXX			
Signal + power supply			
Cable	Color	Voltage	Current
	GY	0...10 VDC or 10...0 VDC	4(0)...20 mA or 20... 4(0) mA
	PK	DC Ground	DC Ground
	YE	0...10 VDC or 10...0 VDC	4(0)...20 mA or 20... 4(0) mA
	GN	DC Ground	DC Ground
	BN	+24 VDC (-15 / +20 %)	+24 VDC (-15 / +20 %)
	WH	DC Ground (0 V)	DC Ground (0 V)

Fig. 17: Connector wiring TXX / VXX

4.5 Frequently ordered accessories – Additional options available in our [Accessories Guide](#) 551 444





Position magnets			
<p>Ring magnet OD33 Part no. 201 542-2</p>	<p>Ring magnet OD25.4 Part no. 400 533</p>	<p>Ring magnet OD17.4 Part no. 401 032</p>	<p>U-magnet OD33 Part no. 251 416-2</p>
<p>Material: PA ferrite GF20 Weight: Approx. 14 g Surface pressure: Max. 40 N/mm² Fastening torque for M4 screws: 1 Nm Operating temperature: -40...+105 °C (-40...+221 °F)</p>	<p>Material: PA ferrite Weight: Approx. 10 g Surface pressure: Max. 40 N/mm² Operating temperature: -40...+105 °C (-40...+221 °F)</p>	<p>Material: PA neobind Weight: Approx. 5 g Surface pressure: Max. 20 N/mm² Operating temperature: -40...+105 °C (-40...+221 °F)</p>	<p>Material: PA ferrite GF20 Weight: Approx. 11 g Surface pressure: Max. 40 N/mm² Fastening torque for M4 screws: 1 Nm Operating temperature: -40...+105 °C (-40...+221 °F)</p>

Position magnet	Magnet spacer	Optional installation hardware	
<p>U-magnet OD63.5 Part no. 201 553</p>	<p>Magnet spacer Part no. 400 633</p>	<p>O-ring for flange M18x1.5-6g Part no. 401 133</p>	<p>O-ring for flange 3/4"-16 UNF-3A Part no. 560 315</p>
<p>Material: PA 66-GF30, Magnets compound-filled Weight: Approx. 26 g Surface pressure: 20 N/mm² Fastening torque for M4 screws: 1 Nm Operating temperature: -40...+75 °C (-40...+167 °F)</p>	<p>Material: Aluminum Weight: Approx. 5 g Surface pressure: 20 N/mm² Fastening torque for M4 screws: 1 Nm</p>	<p>Material: Fluoroelastomer 75 ± 5 durometer Operating temperature: -40...+204 °C (-40...+400 °F)</p>	<p>Material: Fluoroelastomer 75 ± 5 durometer Operating temperature: -40...+204 °C (-40...+400 °F)</p>

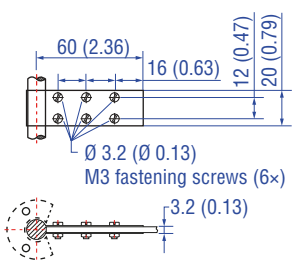
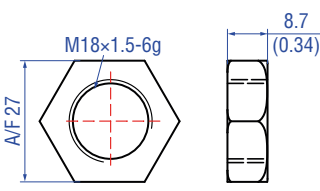
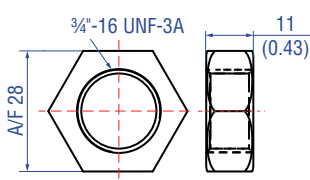
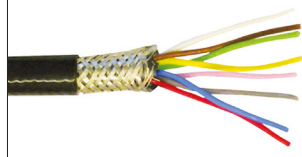
Manuals, Software & 3D Models available at:
www.mtssensors.com

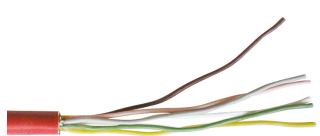
Controlling design dimensions are in millimeters and measurements in () are in inches

Optional installation hardware			Cable
			
Fixing clip Part no. 561 481	Hex jam nut M18x1.5-6g Part no. 500 018	Hex jam nut 3/4"-16 UNF-3A Part no. 500 015	Teflon® cable Part no. 530 112
Application: Used to secure sensor rods (Ø 10 mm (Ø 0.39 in.)) when using an U-magnet Material: Brass, non-magnetic	Material: Steel, zinc, plated	Material: Zinc plated with nylon insert	Name of cable in order code: T Material: Teflon® jacket; black Features: Twisted pair shielded Cable Ø: 7.6 mm (0.3 in.) Dimensions: 4 × 2 × 0.25 mm ² Bending radius: 8 – 10 × Ø (fixed installation) Operating temperature: –100...+180 °C (–148...+356 °F)

Cable	Programming tools ⁴		
			
Silicone cable Part no. 530 113	Analog hand programmer Part no. 253 124	Analog cabinet programmer Part no. 253 408	Programming kit Part no. 254 555
Name of cable in order code: V Material: Silicone jacket; red Features: Twisted pair, shielded Cable Ø: 7.2 mm (0.3 in.) Dimensions: 3 × 2 × 0.25 mm ² Bending radius: 5 × Ø (fixed installation) Operating temperature: –50...+180 °C (–58...+356 °F)	Easy teach-in-setups of stroke length and direction on desired zero / span positions. For sensors with 1 magnet.	Features snap-in mounting on standard 35 mm DIN rail. This programmer can be permanently mounted in a control cabinet and includes a program / run switch. For sensors with 1 magnet.	Kit includes: Interface converter box, power supply, cable Software is available at: www.mtssensors.com

Manuals, Software & 3D Models available at:
www.mtssensors.com

Controlling design dimensions are in millimeters and measurements in () are in inches

4/ The programming tools are not approved for use in hazardous environments

5. Operation

5.1 Getting started

The sensor is factory-set to its order sizes and adjusted, i.e. the required output signal corresponds exactly to the selected stroke length.

Example: Output 4...20 mA = 0...100 % stroke length

NOTICE If necessary, the analog sensors can be re-adjusted using the service tools described below.

NOTICE

Observe during commissioning

1. Before switching on for the first time, check the connection of the sensor carefully.
2. Position the magnet in the measuring range of the sensor during first commissioning and after replacement of the magnet.
3. Ensure that the sensor control system cannot be displaced in an uncontrolled way when switching on.
4. Ensure that the sensor is ready and in operation mode after switching on.
5. Check the pre-set span start and end values of the measuring range (Fig. 13) and correct them via the customer's control system if necessary, or via the MTS Sensors service tools. The operation of the service tools is described in detail on the following pages.

5.2 Programming and configuration

Analog interface

The analog sensor can be directly connected to a controller. Its electronics generates a position signal output proportional to the start and end of the active measuring range.

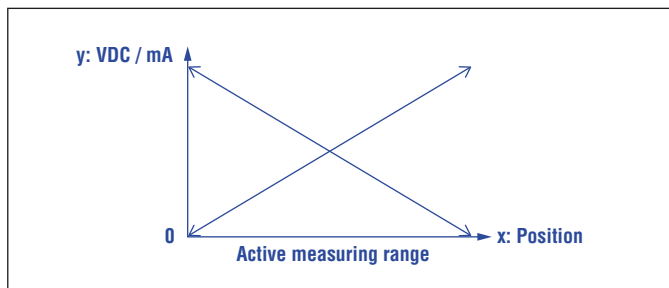

Fig. 18: Analog interface

MTS Sensors programming tools

Temposonics® position sensors can be adapted to modified measurement tasks very easily via the connecting leads – without opening the sensor. Various MTS Sensors programming tools from the list of accessories (see page 13) are available for this purpose.

NOTICE The programming tools are not approved for use in a hazardous environment.

5.2.1 Analog hand programmer, part no. 253 124

Connect the hand programmer directly to the sensor. It is possible to change the start and end positions as well as the measuring direction via simple teach in process, see also “5.2.4 Setting examples for programming tools” on page 21. After that, the changed parameters are stored in the sensor. Move the position magnet to the desired start or end position and push the corresponding “0 %” or “100 %” button on the hand programmer. The minimum distance between the new set-points is 25 mm (1 in.). The individual steps are explained in the following section.

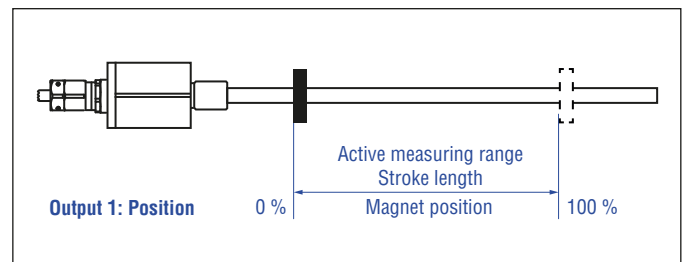

Fig. 19: Active measuring range

Step 1: Connect hand programmer

Step 2: Adjust measuring range

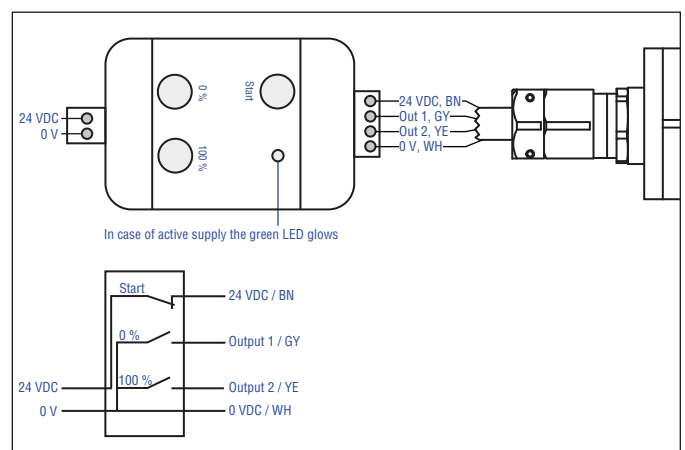

Fig. 20: Connect hand programmer (see connection wiring Fig. 17)

Connect the hand programmer to the power supply and to the sensor according to Fig. 20.

NOTICE
You can only adapt magnet 1 via hand programmer. In order to change the settings of magnet 1 you have to connect both outputs (output 1 and output 2).

3. Set end position (100 % output) (Fig. 22):
 - Set the position magnet on end position
 - Press and release the “100 %” button
4. Back to normal function (operation mode):
 - Press “Start” button
 - Connect the sensor to control unit

- Step 1: Connect hand programmer
- Step 2: Adjust measuring range**

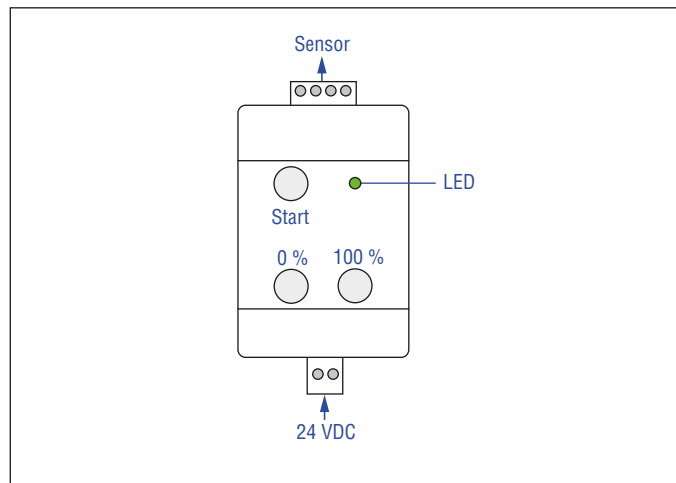

Fig. 21: Adjust measuring range

1. Activate programming mode:
 - Press “Start” button and “100 %” button simultaneously
 - Release “Start” button first, wait 1 second and release “100 %” button
2. Set start position (0 % output) (Fig. 22):
 - Set the position magnet on start position
 - Press and release the “0 %” button

Output from order code	Output 1		Output 2	
	Start position (0 % output)	End position (100 % output)	Start position (0 % output)	End position (100 % output)
V01	0 VDC	10 VDC	—	—
V11	10 VDC	0 VDC	—	—
V03	0 VDC	10 VDC	10 VDC	0 VDC
V02	0 VDC	10 VDC	0 VDC *	10 VDC *
V12	10 VDC	0 VDC	10 VDC *	0 VDC *
A01	4 mA	20 mA	—	—
A11	20 mA	4 mA	—	—
A03	4 mA	20 mA	20 mA	4 mA
A02	4 mA	20 mA	4 mA *	20 mA *
A12	20 mA	4 mA	20 mA *	4 mA *

* When using the analog hand programmer only the start and end positions of magnet 1 (output 1) are adjusted. The settings of magnet 2 (output 2) are not affected.

Fig. 22: Determine start and end position

5.2.2 Analog cabinet programmer, part no. 253 408

Install the built-in programming unit firmly in the control cabinet. It is possible to change the start and end positions as well as the measuring direction via simple teach in process, see also “5.2.4 Setting examples for programming tools” on page 21. After that, the changed parameters are stored in the sensor. Move the position magnet to the desired start or end position and push the corresponding “0 %” or “100 %” button on the hand programmer. The minimum distance between the new setpoints is 25 mm (1 in.). The individual steps are explained in the following section.

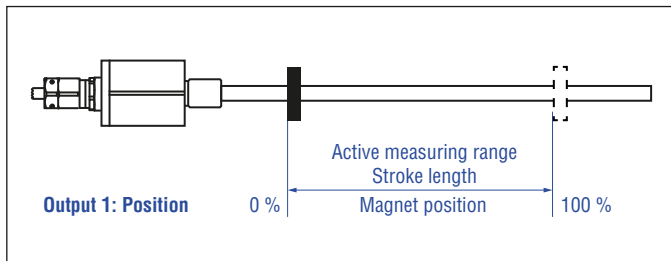

Fig. 23: Active measuring range

- Step 1: Install cabinet programmer**
- Step 2: Connect cabinet programmer
- Step 3: Adjust measuring range

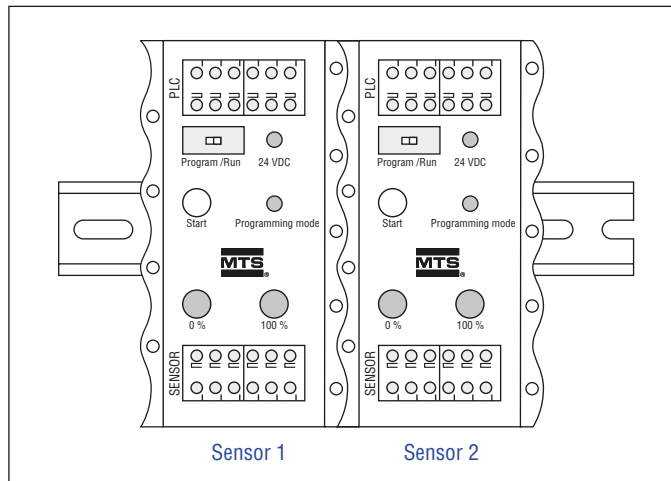

Fig. 24: Dimensions: 10 × 55 × 31 mm (0.39 × 2.17 × 1.22 in.); material: Aluminum, side caps PA 6.6 FR; connection type: Spring terminals, max. 1.5 mm²; ingress protection: IP20

The cabinet programmer is designed for mounting on standard 35 mm (1.38 in.) rails according to DIN EN 60715 / 50022. Install the cabinet programmer between sensor and controller e.g. in a control cabinet. Using the cabinet programmer the sensor can be easily re-programmed as needed with no additional tools.

- Step 1: Install cabinet programmer
- Step 2: Connect cabinet programmer**
- Step 3: Adjust measuring range

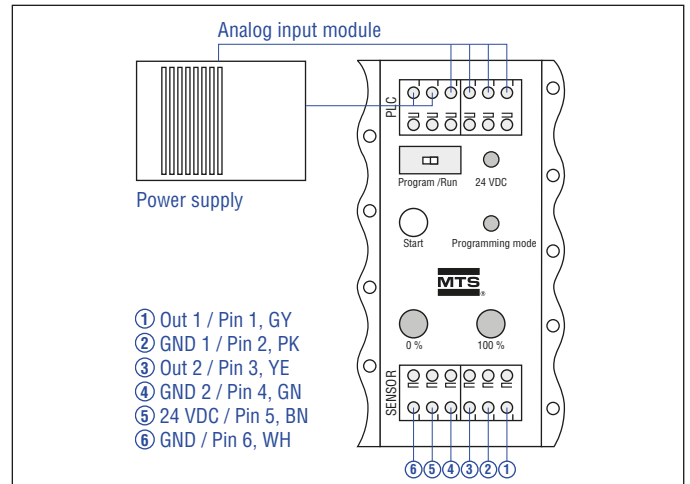

Fig. 25: Connect cabinet programmer (see connector wiring Fig. 17)

Connect the cabinet programmer to the controller, to the power supply and to the sensor according to Fig. 25.

- Step 1: Install cabinet programmer
- Step 2: Connect cabinet programmer
- Step 3: Adjust measuring range**

1. Activate programming mode:

- Slide switch to “Program”
- Press “Start” button and “100 %” button simultaneously
- Release “Start” button first, wait 1 second and release “100 %” button
- Green “Programming mode” LED on cabinet programmer flashes (programming mode reached)

Point 2 – 4 on the next page

2. Set start position (0 % output) (Fig. 26):

- Set the position magnet to start position
- Press and release the “0 %” button

Output from order code	Output 1		Output 2	
	Start position (0 % output)	End position (100 % output)	Start position (0 % output)	End position (100 % output)
V01	0 VDC	10 VDC	—	—
V11	10 VDC	0 VDC	—	—
V03	0 VDC	10 VDC	10 VDC	0 VDC
V02	0 VDC	10 VDC	0 VDC *	10 VDC *
V12	10 VDC	0 VDC	10 VDC *	0 VDC *
A01	4 mA	20 mA	—	—
A11	20 mA	4 mA	—	—
A03	4 mA	20 mA	20 mA	4 mA
A02	4 mA	20 mA	4 mA *	20 mA *
A12	20 mA	4 mA	20 mA *	4 mA *

* When using the analog hand programmer only the start and end positions of magnet 1 (output 1) are adjusted. The settings of magnet 2 (output 2) are not affected.

Fig. 26: Determine start and end position

3. Set end position (100 % output) (Fig. 26):

- Set the position magnet to end position
- Press and release the “100 %” button

4. Back to normal function (operation mode):

- Press and release the “Start” button
- LED “Programming mode” stops flashing
- Slide switch to “Run”
- Green LED “24 VDC” shows normal function

5.2.3 Programming kit, part no. 254 555

The PC programmer is a hardware converter between sensor and serial PC interface. It can be used for adjusting sensor parameters via computer and the MTS Sensors programming software, see also “5.2.4 Setting examples for programming tools” on page 21. The software for reading and adjusting the sensors requires a Windows computer with a free USB port. You can adjust the following parameters:

- Start / end position (min. 25 mm (1 in.) between new setpoints)
- Output signal if errors occur (e.g. no position magnet)

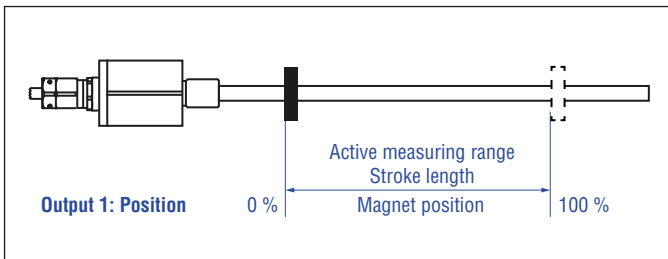

Fig. 27: Active measuring range

- Step 1: Connect PC programmer**
- Step 2: Install software
- Step 3: Start program

- Connect the PC programmer with the sensor via the corresponding adapter cable
- Connect the PC programmer to a USB port of the computer
- Connect the power supply via connector
The outer contact of the connector is 0 V (ground), the inner contact is 24 VDC

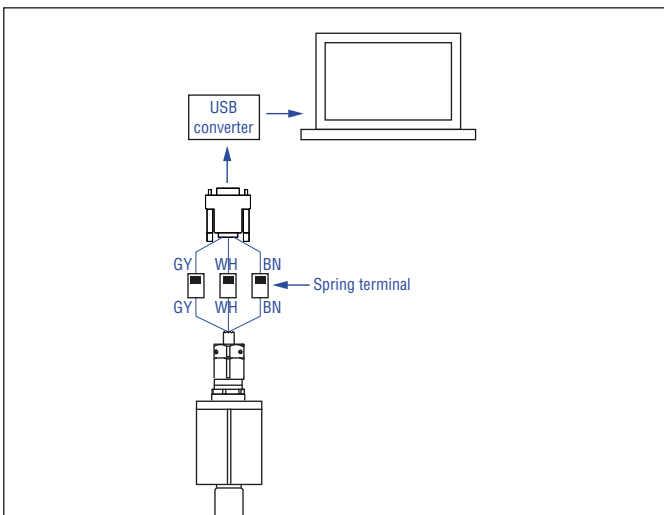

Fig. 28: Connect PC programmer

NOTICE

Never connect / disconnect the sensor when voltage is applied.

- Step 1: Connect PC programmer
- Step 2: Install software**
- Step 3: Start program

Download the current software version from www.mtssensors.com. Copy the program MTSAnalogConfigurator.exe to your computer and start the program. The program now displays a list of available COMs. A free COM port is selected. The COM port, which was chosen, is displayed in the Device Manager. If a connection fails, it could be a missing driver. In this case, download and install the USB serial converter driver from www.mtssensors.com.

- Step 1: Connect PC programmer
- Step 2: Install software
- Step 3: Start program**

After starting the program, the user interface of the connected sensor with its adjustable parameters will open (Fig. 29).

MTS ET Analog software user interface

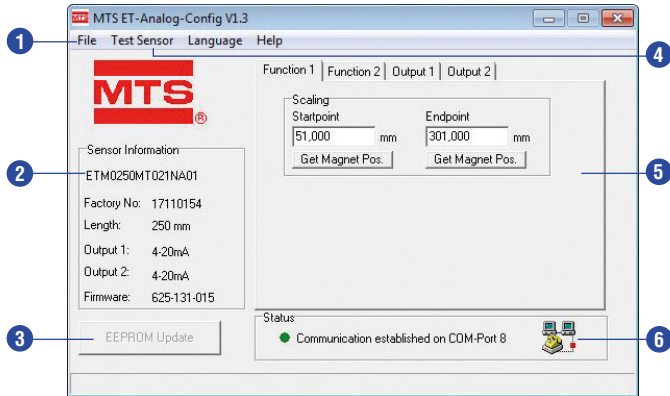

Fig. 29: MTS ET-Analog-Config V1.3, Function 1

- 1 In the **File** menu the sensor configuration can be saved on hard disk, printed out or loaded into the sensor⁵. Moreover, this menu permits returning to the factory setting (Fig. 29).
- 2 **Sensor Information** contains the invariable sensor parameters, which were read in automatically when connecting the sensor. (Fig. 29).
- 3 Any changes which were made are shown with dark background. By clicking on **EEPROM Update** the altered parameters are stored in the sensor permanently. Subsequently, the stored values are displayed again with a white background (Fig. 29).
- 4 Menu **Test Sensor** provides a data display (Fig. 32), which shows the absolute position of the position magnet. Compared with the sensor measuring rate, the serial data transmission between sensor and PC is relatively slow, i.e. not every measured value can be displayed. For this reason, only every 50th measurement value appears in the diagram.
- 5 The control tabs of the main display section permit allocation of functions to the sensor outputs. The measuring range of the functions will be determined in **Scaling** (Fig. 29).
- 6 **Status** indicates that the sensor is connected successfully (Fig. 29).

Dialog field with tabs

- 7 Determine the measuring range with **Startpoint** and **Endpoint** via tab **Function 1** (Fig. 30).
- 8 The current magnet position can be stored via buttons **Get Magnet Pos..**. The measuring direction changes, when the value of the **startpoint** is higher than the value of the **endpoint**. Independent of the measuring direction, the minimum measuring distance is 25 mm (Fig. 30).
- 9 The field **Output Minimum** indicates the current or voltage value which should be output at the startpoint of the selected function. The output value pertaining to the endpoint must be specified in field **Output Maximum** (Fig. 31).

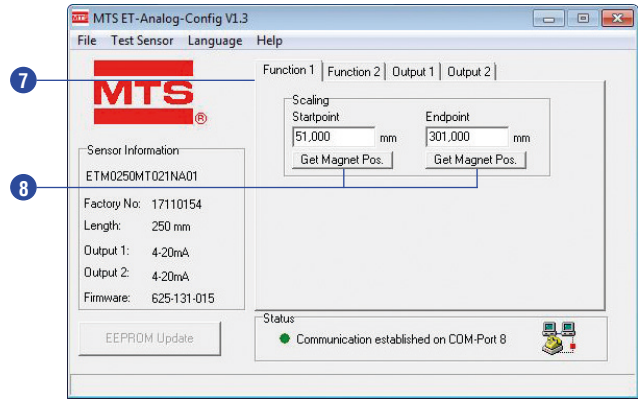

Fig. 30: Dialog field with tabs

- 10 On tabs **Function 2**, **Output 2**, the second analog output can be set (Fig. 31).
- 11 On tab **Output 1** the corresponding analog output signals can be allocated (Fig. 31).
- 12 Unless a position magnet is missing or if it is in the sensor's dead zone, i.e. out of measuring range, **Global Error** is output. The error value can be adjusted within **-0.7...20.3 mA** or **-0.4...10.4 VDC** (Fig. 31).

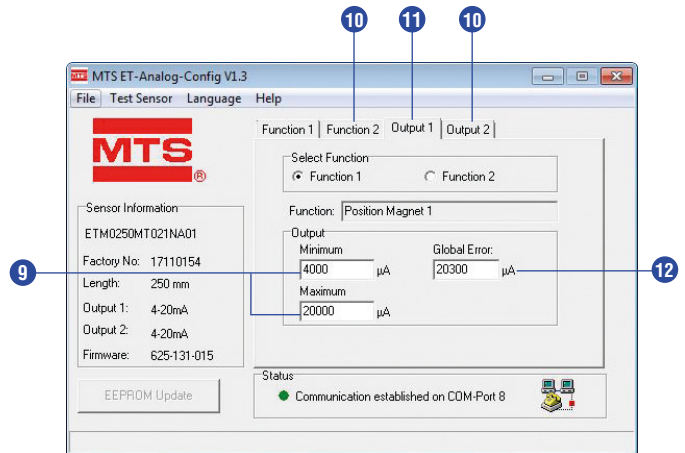

Fig. 31: Example of tab controls

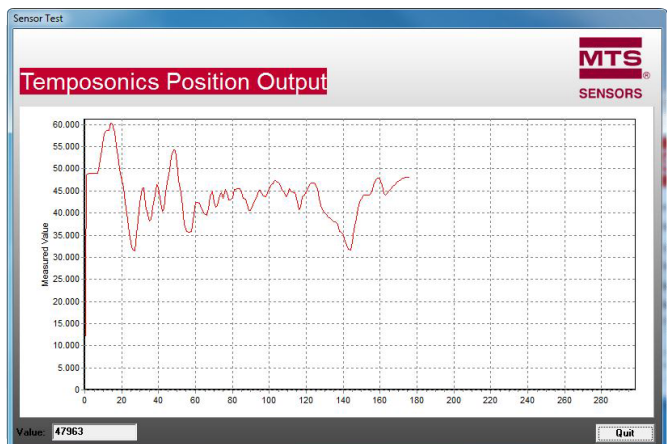

Fig. 32: Data display

5/ Only sensor configurations with the same serial number are permissible

5.2.4 Setting examples for programming tools

The sensor's measuring range can be repositioned using the tools described above at any time.

NOTICE

Independent of the measuring direction, the location of the setpoints in the factory settings is always: SP1 (set point 1) at sensor electronics housing and SP2 (set point 2) at rod end. (Fig. 33).

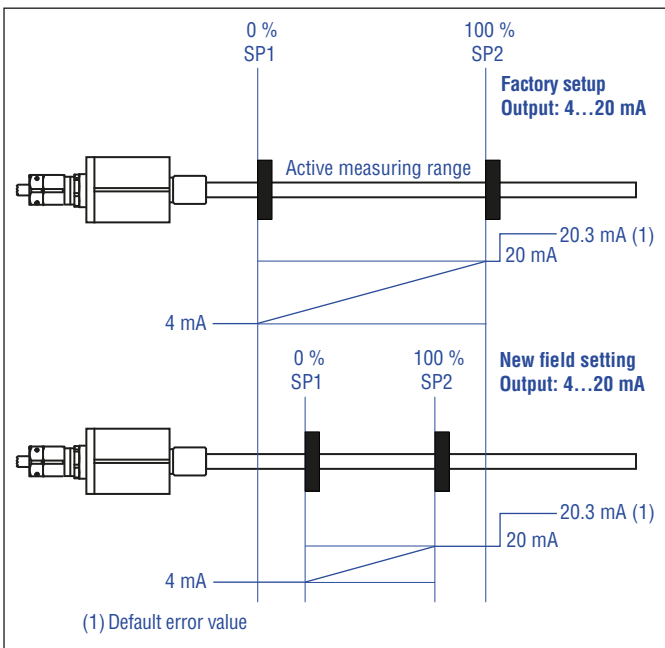

Fig. 33: Adjust start and end position

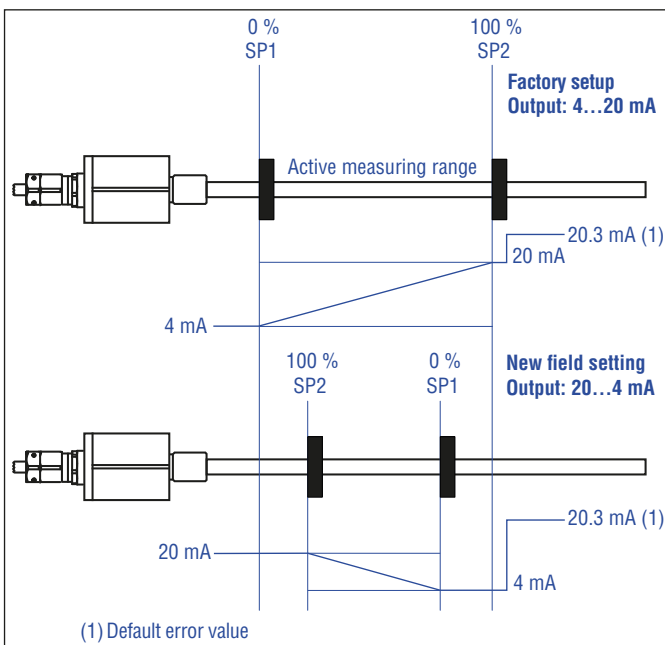

Fig. 34: Start and end position, adjustment / reversal of measuring direction

6. Maintenance and troubleshooting

6.1 Error conditions, troubleshooting

Error condition	Status
Magnet error	Default error value at output: Voltage output: 10.35 V Current output: 20.3 mA Adapted error value at output: -0.7...20.3 mA or -0.4...10.4 VDC (see 12 on page 20)

6.2 Maintenance

The required inspections need to be performed by qualified personnel according to IEC 60079-17 / TRBS 1203. These inspections should include at least a visual inspection of the housing, associated electrical equipment entrance points, retention hardware and equipment grounding. Inside the Ex-atmosphere the equipment has to be cleaned regularly. The user determines the intervals for checking according to the environmental conditions present at the place of operation. After maintenance and repair all protective devices removed for this purpose must be refitted.

In case of equipment faults, remove the equipment. The inner parts cannot be maintained by the customer. In this case send the equipment to the manufacturer for inspection.

NOTICE

It is not allowed to open the sensor.

Type of inspection	Visual inspection every 3 months	Close inspection every 6 months
Visual inspection of the sensor for intactness, removal of dust deposits	●	
Check of entire system	User's responsibility	

Fig. 35: Schedule of inspection

Maintenance: Defines a combination of any actions carried out to retain an item in, or restore it to, conditions in which it is able to meet the requirements of the relevant specification and perform its required functions.

Inspection: Defines an activity with the purpose to check a product carefully, aiming at a reliable statement on the condition of the product. The inspection is carried out without dismantling, or, if necessary, with partial dismantling, and supplemented by other measures, e.g. measurements.

Visual inspection: Optical inspection of product aims at the recognition of visible defects like missing bolts without using auxiliary equipment and tools.

Close inspection: Defines an inspection which encompasses those aspects covered by a visual inspection and, in addition, identifies those defects, such as loose bolts, which will be apparent only by the use of access equipment, for example steps, where necessary, and tools.

6.3 Repair

Repairs on the sensor may be performed only by MTS Sensors or an explicitly authorized body.

6.4 List of spare parts

No spare parts are available for this sensor.

6.5 Transport and storage

The conditions of transport and storage of the sensor match the operating conditions mentioned in this document.

7. Removal from service / dismantling

The product contains electronic components and must be disposed of in accordance with the local regulations.

8. Technical data of Temposonics® ET

Output	
Voltage	0...10 VDC and / or 10...0 VDC (minimum load controller: > 5 kΩ)
Current	4(0)...20 mA and / or 20...4(0) mA (minimum / maximum load: 0 / 500 Ω)
Measured value	Position
Measurement parameters	
Resolution	16 bit (minimum 1 μm depending on stroke length) ⁶
Cycle time	Stroke length 50...1200 mm: 0.5 ms Stroke length 1201...2400 mm: 1.0 ms Stroke length 2401...3000 mm: 2.0 ms
Linearity ⁷	≤ ±0.02 % F.S. (minimum ±60 μm)
Repeatability	≤ ±0.005 % F.S. (minimum ±20 μm) typical
Operating conditions	
Operating temperature	-40...+85 °C (-40...+185 °F)
Humidity	90 % relative humidity, no condensation
Ingress protection	Version A and E with Teflon® cable (part no. 530 112): IP66 Version A, E and N with silicone cable (part no. 530 113): IP68 (2 bar (29 psi) @ 30 min)
Shock test	100 g (single shock), IEC standard 60068-2-27
Vibration test	15 g / 10...2000 Hz, IEC standard 60068-2-6 (resonance frequencies excluded)
EMC test	Electromagnetic emission according to EN 61000-6-4 Electromagnetic immunity according to EN 61000-6-2 The sensor meets the requirements of the EU directives and is marked with CE
Operating pressure	Up to 350 bar (5076 psi)
Magnet movement velocity ⁸	Any
Design / Material	
Sensor electronics housing	Stainless steel 1.4305 (AISI 303); option: Stainless steel 1.4404 (AISI 316L)
Flange	Stainless steel 1.4305 (AISI 303); option: Stainless steel 1.4404 (AISI 316L)
Sensor rod	Stainless steel 1.4306 (AISI 304L); option: Stainless steel 1.4404 (AISI 316L)
Stroke length	50...3000 mm (1...118 in.)
Mechanical mounting	
Mounting position	Any
Mounting instruction	Please consult the technical drawings on page 8
Electrical connection	
Connection type	Cable outlet
Operating voltage	+24 VDC (-15 / +20 %)
Ripple	≤ 0.28 V _{pp}
Current consumption	100 mA typical, dependent on stroke length
Dielectric strength	700 VDC (DC ground to machine ground)
Polarity protection	Up to -30 VDC
Overvoltage protection	Up to 36 VDC

6/ The internal digital value is transferred via a 16-bit D/A converter into a proportional, analog current or voltage signal

7/ With position magnet # 251 416-2

8/ If there is contact between the moving magnet including the magnet holder and the sensor rod, make sure that the maximal speed of the moving magnet is ≤ 1 m/s (ATEX requirement due to ESD [Electro Static Discharge])

Certification
⊕ II 3G Ex nC IIC T4 Gc
⊕ II 3D Ex tc IIIC T130 °C Dc IP66 / IP68
Class I/II/III Div 2 T4 ABCDFG
Class I Zone 2 T4 IIC
Zone 22 AEx tc T4 IIIC Dc
-40 °C ≤ Ta ≤ 85 °C, Type: 4X

Fig. 36: Certification of Temposonics® ET (version A and E)

9. Appendix

Safety Declaration

Dear Customer,

If you return one or several sensors for checking or repair, we need you to sign a safety declaration. The purpose of this declaration is to ensure that the returned items do not contain residues of harmful substances and / or that people handling these items will not be in danger.

MTS Sensors order number: _____ Sensor type(s): _____

Serial number(s): _____ Sensor length(s): _____

The sensor has been in contact with the following materials:

Do not specify chemical formulas.
Please include safety data sheets of the substances, if applicable.

In the event of suspected penetration of substances into the sensor, consult MTS Sensors to determine measures to be taken before shipment.

Short description of malfunction:

Corporate information

Company: _____

Address: _____

Contact partner

Name: _____

Phone: _____

E-mail: _____

We hereby certify that the measuring equipment has been cleaned and neutralized.
Equipment handling is safe. Personnel exposure to health risks during transport and repair is excluded.

Stamp

GERMANY
MTS Sensor Technologie GmbH & Co. KG
Auf dem Schüffel 9
58513 Lüdenscheid, Germany
Tel. +49-23 51-95 87 0
Fax. +49-23 51-5 64 91
info.de@mtssensors.com
www.mtssensors.com

Signature

USA
MTS Systems Corporation Sensors Division
3001 Sheldon Drive
Cary, N.C. 27513, USA
Tel. +1 919 677-0100
Fax +1 919 677-0200
info.us@mtssensors.com
www.mtssensors.com

Date

JAPAN
MTS Sensors Technology Corp.
737 Aihara-machi,
Machida-shi,
Tokyo 194-0211, Japan
Tel. +81 42 775-3838
Fax +81 42 775-5512
info.jp@mtssensors.com
www.mtssensors.com

EU Declaration of Conformity
EU-Konformitätserklärung
Déclaration UE de Conformité

EC17.004A

MTS Sensor Technologie GmbH & Co. KG, Auf dem Schueffel 9, 58513 Luedenscheid, Germany

declares as manufacturer in sole responsibility that the position sensor type
erklärt als Hersteller in alleiniger Verantwortung, dass der Positionssensor Typ
déclare en qualité de fabricant sous sa seule responsabilité que les capteurs position de type

Temposonics	ET-x-xxxxx-Txx-1-N-aaa	aaa = V01, V02, V03, V11, V12
	ET-x-xxxxx-Vxx-1-N-aaa	A01, A02, A03, A11, A12
	ET-x-xxxxx-Txx-1-N-Sxxxxxx	
	ET-x-xxxxx-Vxx-1-N-Sxxxxxx	

comply with the regulations of the following European Directives:
den Vorschriften folgender Europäischen Richtlinien entsprechen:
sont conformes aux prescriptions des directives européennes suivantes :

2014/30/EU	Electromagnetic Compatibility Elektromagnetische Verträglichkeit Compatibilité électromagnétique
-------------------	--

Applied harmonized standards:
Angewandte harmonisierte Normen:
Normes harmonisées appliquées :

EN 61000-6-2:2005, EN 61000-6-4:2007+A1:2011

Luedenscheid, 2017-06-30

MTS Sensor Technologie GmbH & Co. KG, Auf dem Schueffel 9, 58513 Luedenscheid, Germany



Thomas Muckenhaupt
Head of Quality Management



QPS Evaluation Services Inc
Testing, Certification and Field Evaluation Body
Accredited in Canada, the USA, and Internationally

File
LR1346

CERTIFICATE OF COMPLIANCE
(ISO TYPE 3 CERTIFICATION SYSTEM)

Issued to	MTS Sensor Technologie GmbH & Co KG
Address	Auf Dem Schüffel 9, Lüdenscheid, Germany, D-58513
Project Number	LR1346-3
Product	Linear Position Sensors
Model Number	Tempsonics ® E-Series ET (see annex below for full model information)
Ratings/Markings	see annex below for full marking information
Applicable Standards	CSA C22.2 No. 60079-0:2015, CSA C22.2 No. 60079-15:2016, CSA C22.2 No 60079-31:2015, CSA C22.2 No 61010-1:2012, CSA C22.2 94.2:2015 ANSI/ISA 12.12.01 (2015), ANSI/UL 61010-1 (2012), ANSI/UL 50E 2nd Edition, ANSI/UL 60079-0 (2013), ANSI/UL 60079-31 (2015), ANSI/UL 2225 (2013)
Factory/Manufacturing Location	Same as above

Statement of Compliance: The product(s) identified in this Certificate and described in the Report covered under the above referenced project number have been investigated and found to be in compliance with the relevant requirements of the above referenced standard(s). As such, they are eligible to bear the QPS Certification Mark shown below, in accordance with the provisions of QPS's Service Agreement.



Issued By: Dave Adams P.Eng.

Signature:

Date: March 28, 2017



QPS Evaluation Services Inc
Testing, Certification and Field Evaluation Body
Accredited in Canada, the USA, and Internationally

File
LR1346

Annex:

Product: Linear Position Sensors Tempsonics ® E-Series ET
 Models: SSI Output, Analog & Digital Start/Stop

Model (output)	Canada	US
Analog	Ex nC IIC T4 Gc Ex tc IIIC T130°C Dc IP66/68 -40°C ≤Ta≤85°C Type 4X	Class I/II/III Div 2 T4 ABCDFG Class I Zone 2 T4 IIC Zone 22 AEx tc T4 IIIC Dc -40°C ≤Ta≤85°C, Type 4X
Digital Start/Stop	Ex nC IIC T4 Gc Ex tc IIIC T130°C Dc IP66/68 -40°C ≤Ta≤105°C Type 4X	Class I/II/III Div 2 T4 ABCDFG Class I Zone 2 T4 IIC Zone 22 AEx tc T4 IIIC Dc -40°C ≤Ta≤105°C, Type 4X
SSI Output	Ex nC IIC T4 Gc Ex tc IIIC T130°C Dc IP66/68 -40°C ≤Ta≤90°C Type 4X	Class I/II/III Div 2 T4 ABCDFG Class I Zone 2 T4 IIC Zone 22 AEx tc T4 IIIC Dc -40°C ≤Ta≤90°C, Type 4X

*Models are differentiated by output signal type

Each model has its own designated ambient range and dust temperature limitation (see table).

The sensors are supplied with a permanently connected cable with a rated voltage of 24 (-15%, +20%) VDC and a maximum current of 105 mA.

The equipment is intended for permanent field installation.

Model nomenclature below:



IECEX Certificate of Conformity

INTERNATIONAL ELECTROTECHNICAL COMMISSION IEC Certification Scheme for Explosive Atmospheres

for rules and details of the IECEx Scheme visit www.iecex.com

Certificate No.: IECEx CML 16.0125X Issue No: 1 Certificate history:
Status: **Current** Page 1 of 4 [Issue No. 1 \(2017-03-09\)](#)
Date of Issue: **2017-03-09** [Issue No. 0 \(2017-02-23\)](#)

Applicant: **MTS Sensor Technologie GmbH**
Auf Dem Schüffel 9
Ludenscheid
D-58513
Germany

Equipment: **Linear Position Sensor Temposonics E-Series ET**
Optional accessory:

Type of Protection: **Sealed Device "nC", Protection by enclosure "tc"**

Marking:
Ex nC IIC T4 Gc
Ex tc III C T130°C Dc
Refer to Annex for further marking detail.

Approved for issue on behalf of the IECEx
Certification Body:

A Snowdon

Position:

Certification Officer

Signature:
(for printed version)

Date:

March 9, 2017

1. This certificate and schedule may only be reproduced in full.
2. This certificate is not transferable and remains the property of the issuing body.
3. The Status and authenticity of this certificate may be verified by visiting the [Official IECEx Website](#).

Certificate issued by:

Certification Management Limited
Unit 1, Newport Business Park
New Port Road
Ellesmere Port, CH65 4LZ
United Kingdom





Sensor with Ex approval

Document Part Number:
551890 Revision A (EN) 07/2017

LOCATIONS

USA
MTS Systems Corporation
Sensors Division
3001 Sheldon Drive
Cary, N.C. 27513, USA
Tel. +1 919 677-0100
Fax +1 919 677-0200
info.us@mtssensors.com
www.mtssensors.com

JAPAN
MTS Sensors Technology Corp.
737 Aihara-machi,
Machida-shi,
Tokyo 194-0211, Japan
Tel. +81 42 775-3838
Fax +81 42 775-5512
info.jp@mtssensors.com
www.mtssensors.com

FRANCE
MTS Systems SAS
Zone EUROPARC Bâtiment EXA 16
16/18, rue Eugène Dupuis
94046 Creteil, France
Tel. +33 1 58 4390-28
Fax +33 1 58 4390-03
info.fr@mtssensors.com
www.mtssensors.com

GERMANY
MTS Sensor Technologie
GmbH & Co. KG
Auf dem Schüffel 9
58513 Lüdenscheid, Germany
Tel. +49 2351 9587-0
Fax +49 2351 56491
info.de@mtssensors.com
www.mtssensors.com

CHINA
MTS Sensors
Room 504, Huajing Commercial Center,
No. 188, North Qinzhou Road
200233 Shanghai, China
Tel. +86 21 6485 5800
Fax +86 21 6495 6329
info.cn@mtssensors.com
www.mtssensors.com

ITALY
MTS Systems Srl
Sensor Division
Via Camillo Golgi, 5/7
25064 Gussago (BS), Italy
Tel. +39 030 988 3819
Fax +39 030 982 3359
info.it@mtssensors.com
www.mtssensors.com

LEGAL NOTICES

MTS, Temposonics and Level Plus are registered trademarks of MTS Systems Corporation in the United States; MTS SENSORS and the MTS SENSORS logo are trademarks of MTS Systems Corporation within the United States. These trademarks may be protected in other countries. All other trademarks are the property of their respective owners. Copyright © 2017 MTS Systems Corporation. No license of any intellectual property rights is granted. MTS reserves the right to change the information within this document, change product designs, or withdraw products from availability for purchase without notice. Typographic and graphics errors or omissions are unintentional and subject to correction. Visit www.mtssensors.com for the latest product information.

